

Recommendations to maintain duplex OF channel polarity

TECHNICAL PAPER

October 2024 v2.0



Table of Contents

1	Introduction	3
2	Duplex OF channel polarity	4
3	Technical background	5
3.1	Patch cords	5
3.1.1	The "Cross-over" duplex cord	6
3.1.2	The "straight-trough" duplex cord	7
3.2	Adapters.....	8
4	How to maintain OF duplex polarity?	9
5	End-to-end duplex polarity management	10
5.1	Reverse-pair wiring principle	10
5.2	Symmetrical-pair wiring principle	11
5.3	Implementation on site.....	12
5.4	Backbone OF cable termination schemes.....	13
5.5	FD to TO Horizontal OF links	18
5.6	Horizontal OF links with Consolidation Point (CP)	19
6	Conclusions	22

1 Introduction

Today most fibre systems are using duplex OF channels.

That is why Aginode has decided to adapt the production of the LANmark-OF patch cords to better reflect the present needs of the market and ease the design and installation works of the Aginode partners

All Aginode OF patch cords (mainly terminated SC or LC connectors) provide a crossover instead of being straight-through (Refer to paragraph 3.1 for explanations about crossover and straight-through duplex cords).

Part Numbers of these new cords will be structured in another way: N122.XXXXX to easily differentiate them from the previous production.

Example

The part number of the LANmark-OF Slimflex Patch Cord DLC - DLC OM4 LSZH Aqua 2 m will be N122.7LLA2.

This white paper provides descriptions and guidance to be applied to maintain OF system polarity just by using standard Aginode components and by implementing simple design and installation recommendations.

The Aginode OF products and the following recommendations are compliant with the main cabling standards: ISO11801:2017 & EN50173:2018 and subsequent addendums and revisions.

2 Duplex OF channel polarity

Nowadays, most fibre systems are using two fibres, transmitting the signal on one fibre for one direction and on a second fibre for the opposite direction.

It is so important to ensure that the transmit-to-receive polarity is maintained on the most simple and standard way possible.

Duplex presentation of the OF ports is really useful to easily maintain the correct polarity of transmit and receive paths in a channel formed by two fibres.

That is why duplex OF adapters and duplex OF connectors have been created. The use of crossover duplex patch cords is now recommended.

Duplex OF ports of all Ethernet active equipment (or of any equipment within the same application) have the same Transmit and Receive ports position.

Typically, TX is on the left and RX is on the right with the keyway of the duplex adapter on top.

To have a valid duplex communication channel, the TX of switch n°1 has to be connected to the RX of switch n°2 and reverse.

If you connect the two switches together using a standard "crossover" duplex patch cord, the TX to RX polarity is automatically maintained and the communication between the switches is established.

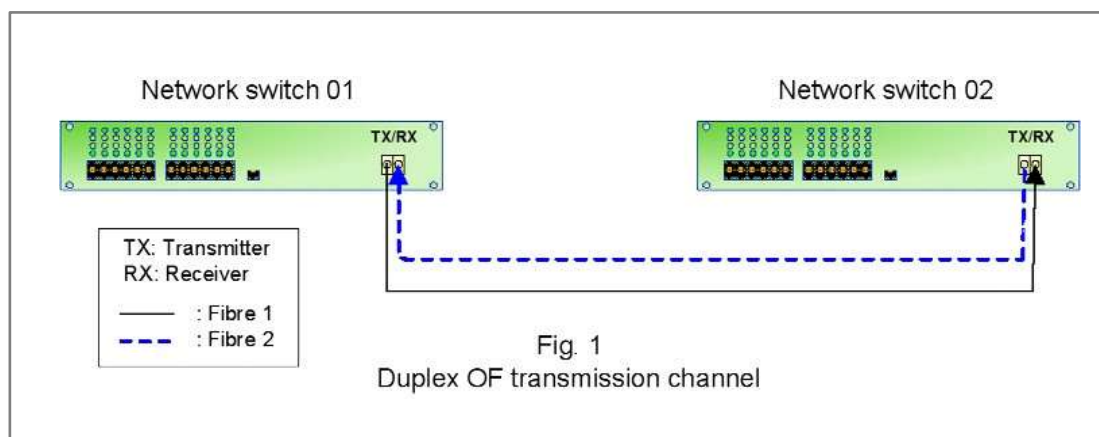

3 Technical background

3.1 Patch cords

Optical fibre connectors are keyed so that the plug can be inserted into the adapter in only one orientation.

If two switches are connected together using a duplex cord, the fibres of the patch cable should be wired in such a way that the transmit-to-receive polarity is respected. In other words, the patch cord has to cause a reversal between the TX and the RX to allow direct connection using standard cords.

When talking about duplex connectors, A & B letters are typically used to designate each connector. Those two letters can be found onto some of the duplex connectors.

There are two different ways to connect two duplex connectors together to produce one duplex patch cord:

- Connector A of the first duplex connector (A1) connected to the connector B of the second duplex connector (B2) and connector B1 connected to A2. (Fig.2)
- Connector A of the first duplex connector (A1) connected to the connector A of the second duplex connector (A2) and connector B1 connected to B2. (Fig.4)

3.1.1 The "Cross-over" duplex cord

Both fibres are connected on position A on one side and on position B on the other side: A1 is connected to B2 and B1 is connected to A2

When laid flat with both duplex connectors keys up (Fig.2), this duplex cord looks straight-through but when connected to the two switches (Fig.3), this cord introduces a reversal between the two fibres. So, it is a Cross-over cord.

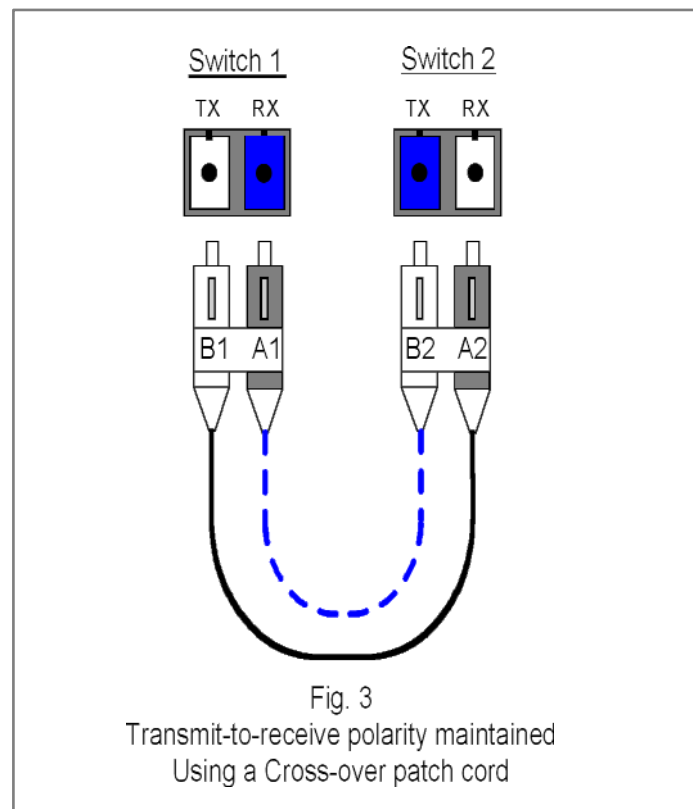
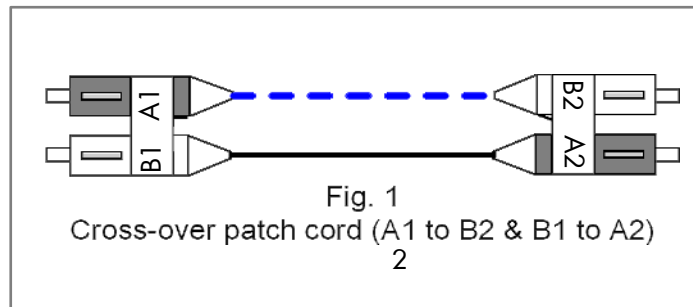

Aginode LANmark-OF patch cords (Mainly DSC, DLC) are compliant with the Cross-over concept.

3.1.2 The "straight-trough" duplex cord

Both fibres are connected on the same A or B position on both sides: A1 is connected to A2 and B1 is connected to B2.

When laid flat with both duplex connectors keys up (Fig.4), this duplex cord looks crossed but when connected to the two switches (Fig.5), this cord does not introduce any reversal between the two fibres. So, it is a straight-through cord.

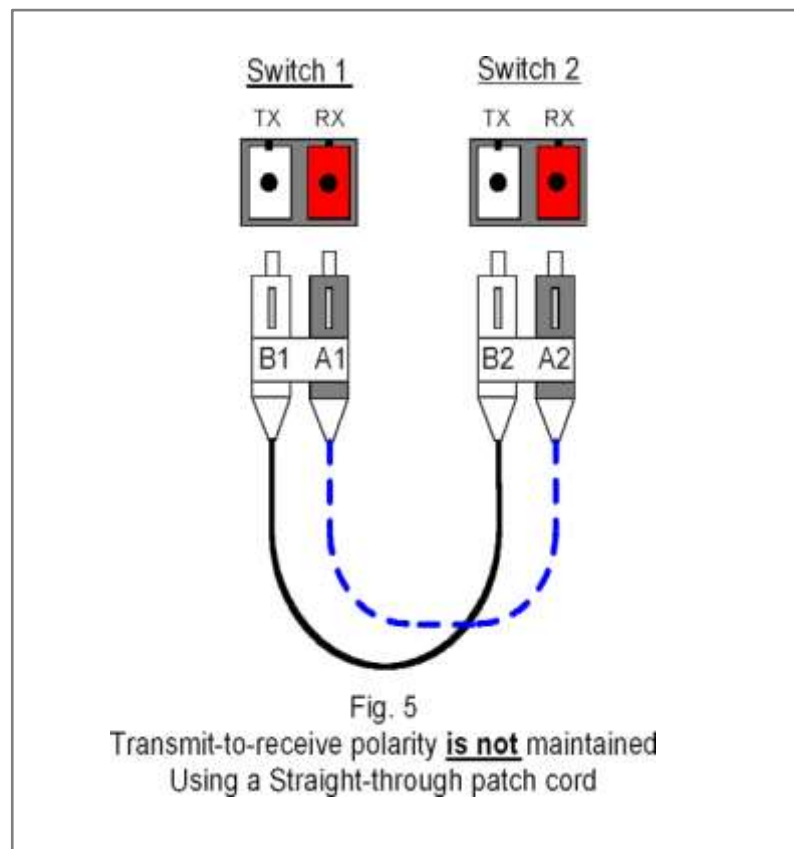
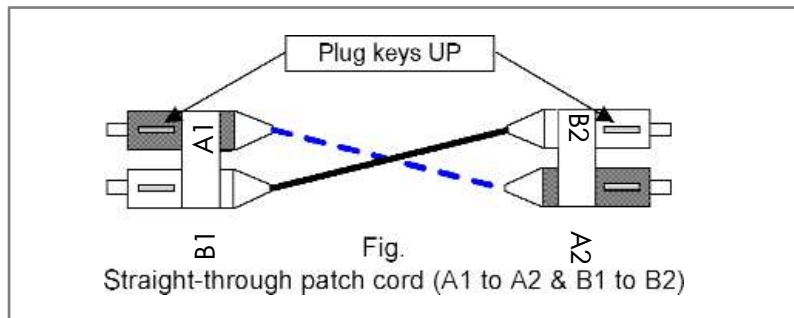

3.2 Adapters

SC and LC duplex adapters have keyways matching the plug keys of the duplex SC and LC connectors and so only allow insertion of the duplex connector into the adapter in one orientation.

Keyways on the front and on the backside of the duplex adapters are on the same face of the adapter. This design is also causing a crossover within the connection: A is connected to B and B to A.

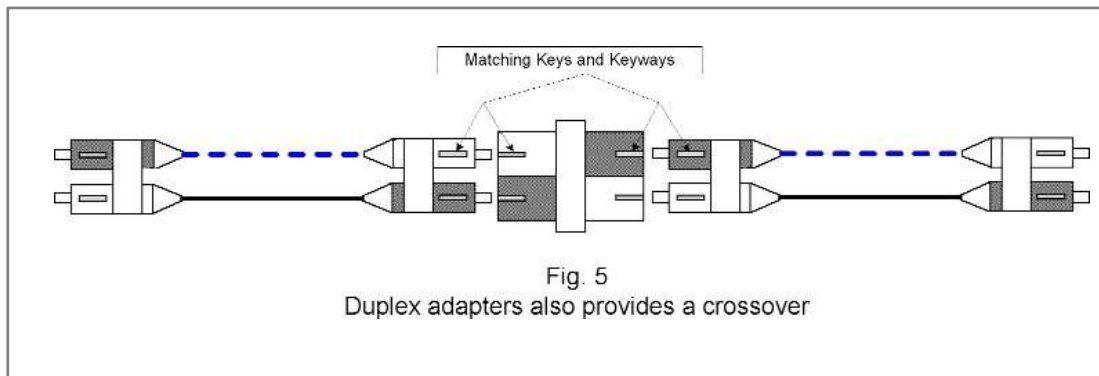

4 How to maintain OF duplex polarity?

The dual OF channel formed by the two Cross-over duplex cords mated together using a duplex adapter, (As shown on figure 6 above) provides a crossover because there is an odd number of crossovers (3) into the dual channel.

As a consequence, the polarity is maintained throughout the dual transmission channel.

An even number of crossovers into a link doesn't provide a resulting crossover between the two transmission channels and so would connect the two TX together and so the two RX together as well.

The following rules should be applied to maintain the duplex polarity

A duplex OF channel must have an odd number of crossovers to maintain the polarity.

Every segment of a channel including all patch cords and all adapters and all OF links (*), shall provides a crossover.

(*): OF links are terminated with OF connectors on both sides. Those links may contain additional permanent joint (fusion splice). These fusion splices do not provide further segmentation.

Important statement:

There are always an odd number of segments into a channel.

Therefore, if every component of the channel is providing a crossover, the duplex polarity will automatically be maintained.

5 End-to-end duplex polarity management

5.1 Reverse-pair wiring principle

As all the patch cords and all the adapters are providing a crossover, the only way to automatically maintain the duplex polarity without having to think about it, is to include a crossover into the OF link segment(s) of the duplex channel as well.

In other words, fibres pairs have to be swapped over (interchanged) on one side of every link segment used to form the duplex channel.

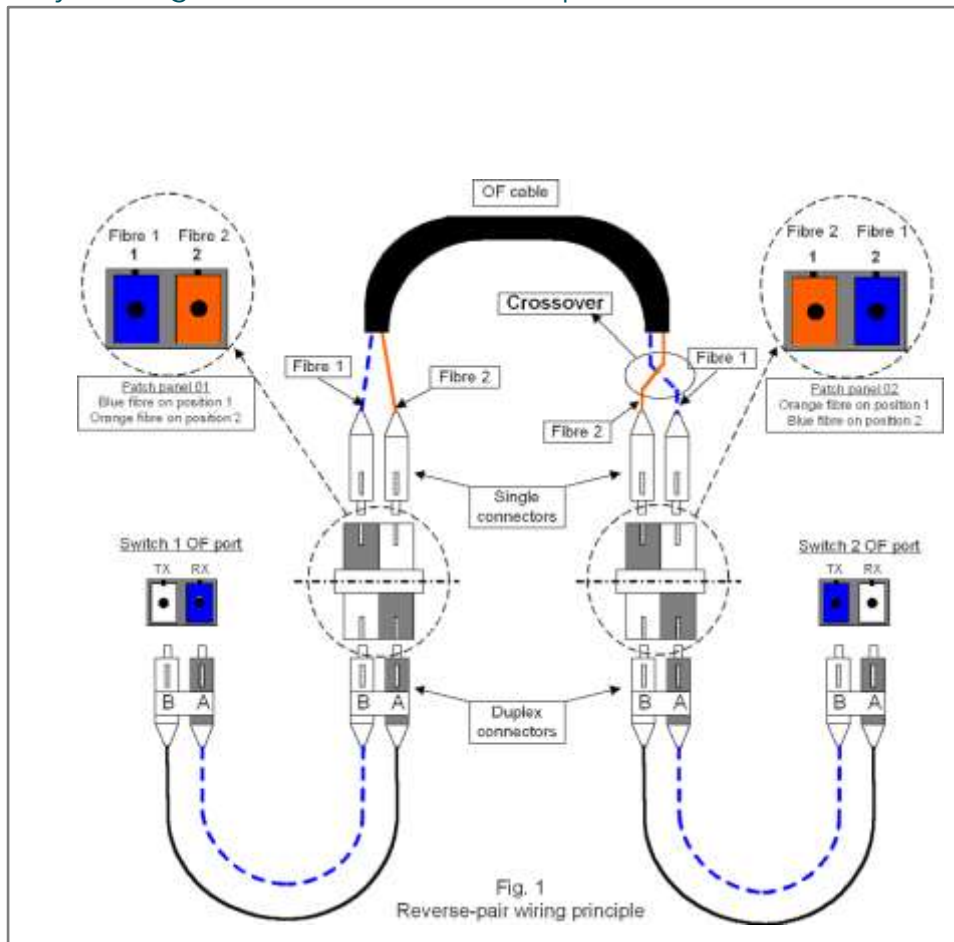

Using this principle is recommended as Data networks are now mainly using duplex transmission channels (Example: Ethernet network). Both ends of a fibre link are not connected to the symmetrical position of the termination patch panels: the fibre n°1 (Blue) is connected on position n°1 of the patch panel on one end and on position n°2 of the patch panel on the other end.

5.2 Symmetrical-pair wiring principle

The following principle can be used to design a generic cabling system whose OF channels are aimed to be used for any telecom applications.

To ease the administration of the MACs and avoid confusion, all the fibres are terminated onto the same position of the patch panel on both ends.

Doing so, the OF link is not providing any crossover when duplex channel are formed, we now have an even number of crossover leading to build non-crossover duplex channel.

We have to come back to an odd number of crossovers. Therefore, on one end of the OF links, the adapters will be installed in the opposite orientation (with the keyways down). It will then oblige the user to turn the duplex connector of the cord upside down to connect it into the adapter and so, the two fibres will be reversed and it will lead to have back an odd number of crossovers.

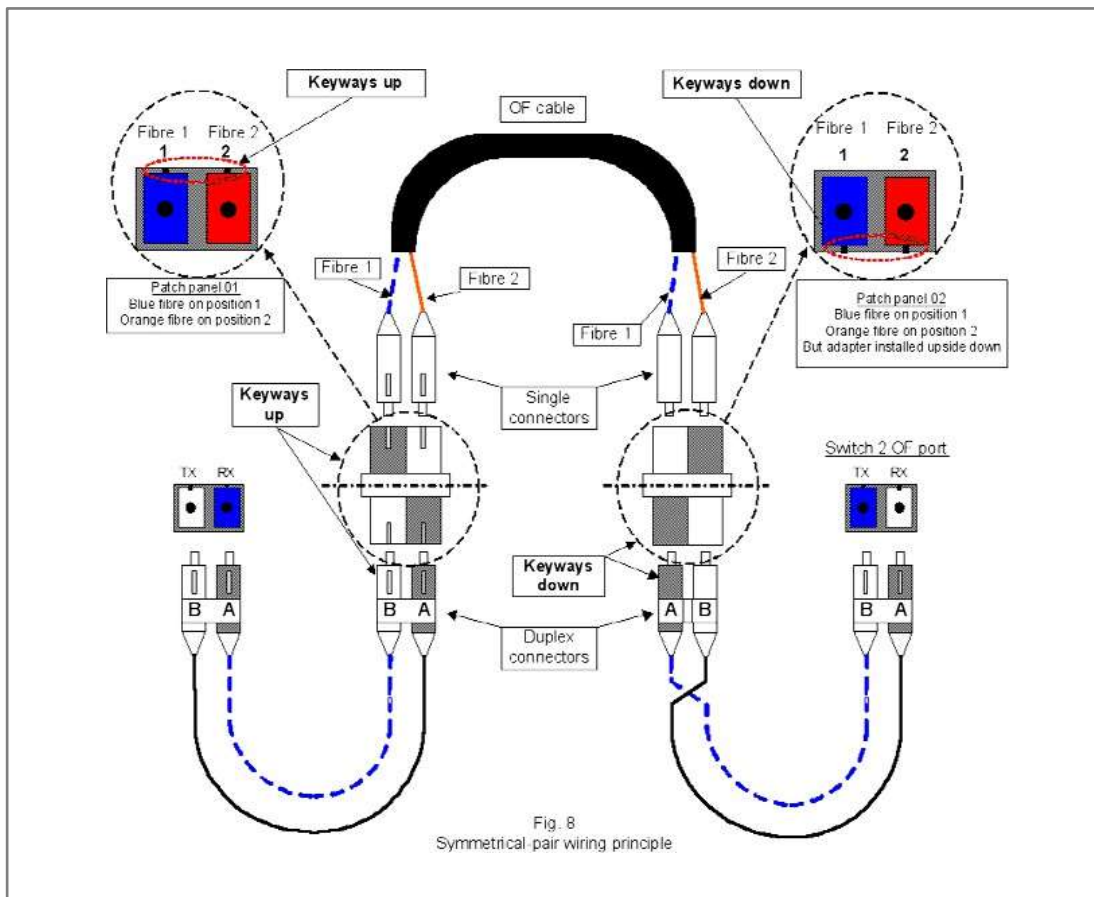

The disadvantage of this principle is that the installer will have to mount the adapters in the opposite way (Upside down) on one side of every OF link.

Important note

The symmetrical-pair wiring method is not applicable to MT-RJ connectors because the two fibres are always connected into one ferrule only (even for the pig-tails) and so repositioning of the fibres on one side only is impossible.

5.3 Implementation on site

Both principles require to differentiate both ends of the OF link.

In order to be consistent and so avoid confusion, it is recommended to implement these principles on site according to the following rules:

Duplex channel polarity	Reverse-pair principle		Symmetrical-pair principle	
	No-crossover	Crossover	Keyway up	Keyway down
Campus backbone	CD (Campus Distributor)	BD (Building Distributor)	CD	BD
Building backbone	BD	FD	BD	FD
Horizontal distribution (HD) or FTDD	FD (Floor Distributor)	TO (Telecom Outlet)	FD (X)	TO (X)
HD / FTDD with Consolidation point : FD to CP	FD	CP (Consolidation point)	FD (X)	CP (X)
HD / FTDD with Consolidation point CP to TO	CP	TO	CP (X)	TO (X)

Table 1: Management of the crossovers within the cabling system

(X): The symmetrical-pair wiring principle should not be used to form horizontal duplex OF channel (FTDD).

5.4 Backbone OF cable termination schemes

The following tables are providing the termination schemes to be implemented according to the recommendations explained in the former chapters.

All four tables are valid for Campus backbones, Building backbones and Horizontal distribution.

The first pair of tables (Tables 2 & 3) is related to reverse-pair wiring showing the way cables have to be terminated on both sides.

The second pair of tables (Tables 4 & 5) is related to the symmetrical-pair wiring.

Two tables are necessary for every principle because the management of the fibres is different when using SC connectors (one fibre per snap-in) and LC connectors (two fibres per snap-in).

The DSC and DLC adapters are factory assembled into the snap-ins plastic hardware. The snap-in cannot be installed in the opposite orientation into the patch panel. Therefore, the adapter has to be removed from the snap-in plastic hardware and re-installed in the opposite orientation.

When working with the snap-in OF connectors, the following guidelines have to be followed to change the orientation of the SC or LC duplex couplers in their snap-in hardware.

1. While keeping the adaptor between two fingers, gently push on the base of the snap-in with the tip of the same fingers
 2. While pushing, push down the adapter clips on both sides of the snap-in using a small screwdriver
 3. Remove the adaptor from the snap-in
 4. Turn it in the opposite orientation (180° turn) to change the orientation of the keys
 5. Click back the adaptor in the snap-in
- For DSC adapters, the keys orientation has to be changed from the upside to the downside (Refer to Table 4).
 - For DLC adapters, the keys orientation has to be changed from the left side to the right side (Refer to Table 5).

Reverse-pair wiring principle (DSC & DLC) OF Cable termination scheme							
1. Duplex SC							
Campus BB: CD side				Campus BB: BD side			
Building BB: BD side				Building BB: FD side			
FTTD: FD side				FTTD: CP side (ZD box)			
Fibre coding		Patch panel		Fibre coding		Patch panel	
Colour	Pair	Position	Adapter Keyways	Colour	Pair	Position	Adapter Keyways
Blue	1	1	Duplex adapter position: Keyways up (by default)	Orange	1	1	Duplex adapter position: Keyways up (by default)
Orange		2		Blue		2	
Green	2	3		Brown	2	3	
Brown		4		Green		4	
Grey	3	5		White	3	5	
White		6		Grey		6	
Red	4	7		Black	4	7	
Black		8		Red		8	
Yellow	5	9		Violet	5	9	
Violet		10		Yellow		10	
Pink	6	11		Turquoise	6	11	
Turquoise		12		Pink		12	
Blue + 1 ring	7	13		Orange + 1 r.	7	13	
Orange + 1 r.		14		Blue + 1 ring		14	
Green + 1 r.	8	15		Brown + 1 r.	8	15	
Brown + 1 r.		16		Green + 1 r.		16	
Grey + 1 r.	9	17		White + 1 r.	9	17	
White + 1 r.		18		Grey + 1 r.		18	
Blue + 2 rings	10	19		Orange + 2 r.	10	19	
Orange + 2 r.		20		Blue + 2 rings		20	
Green + 2 r.	11	21		Brown + 2 r.	11	21	
Brown + 2 r.		22		Green + 2 r.		22	
Grey + 2 r.	12	23		White + 2 r.	12	23	
White + 2 r.		24		Grey + 2 r.		24	

Table 2: Reverse-pair / SC connectors

Reverse-pair wiring principle (DSC & DLC) OF Cable termination scheme							
2. Duplex LC (To be repeated twice for fully loaded patch panel)							
Campus BB: CD side				Campus BB: BD side			
Building BB: BD side				Building BB: FD side			
FTTD: FD side				FTTD: CP side (ZD box)			
Fibre coding		Patch panel		Fibre coding		Patch panel	
Colour	Pair	Position	Adapter Keyways	Colour	Pair	Position	Adapter Keyways
Blue	1	1a	Duplex adapter position: Keyways on the left side (by default)	Orange	1	1a	Duplex adapter position: Keyways on the left side (by default)
Orange		1b		Blue		1b	
Green	2	2a		Brown	2	2a	
Brown		2b		Green		2b	
Grey	3	3a		White	3	3a	
White		3b		Grey		3b	
Red	4	4a		Black	4	4a	
Black		4b		Red		4b	
Yellow	5	5a		Violet	5	5a	
Violet		5b		Yellow		5b	
Pink	6	6a		Turquoise	6	6a	
Turquoise		6b		Pink		6b	
Blue + 1 ring	7	7a		Orange + 1 r.	7	7a	
Orange + 1 r.		7b		Blue + 1 ring		7b	
Green + 1 r.	8	8a		Brown + 1 r.	8	8a	
Brown + 1 r.		8b		Green + 1 r.		8b	
Grey + 1 r.	9	9a		White + 1 r.	9	9a	
White + 1 r.		9b		Grey + 1 r.		9b	
Blue + 2 rings	10	10a		Orange + 2 r.	10	10a	
Orange + 2 r.		10b		Blue + 2 rings		10b	
Green + 2 r.	11	11a		Brown + 2 r.	11	11a	
Brown + 2 r.		11b		Green + 2 r.		11b	
Grey + 2 r.	12	12a		White + 2 r.	12	12a	
White + 2 r.		12b		Grey + 2 r.		12b	

Table 3: Reverse-pair / LC connectors

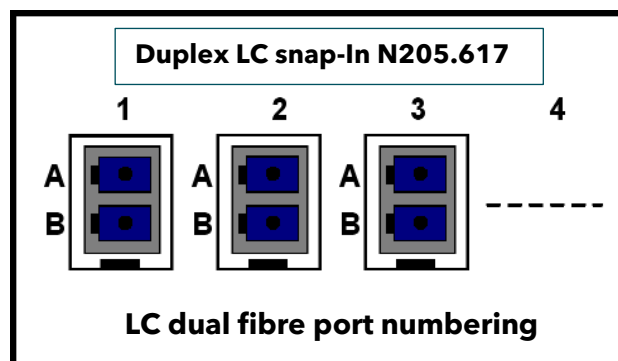

Symmetrical-pair wiring principle OF cable termination scheme							
1. Duplex SC							
Campus BB: CD side Building BB: BD side FTTD: FD side				Campus BB: BD side Building BB: FD side FTTD: CP side (ZD box)			
Fibre coding		Patch panel		Fibre coding		Patch panel	
Colour	Pair	Position	Adapter Keyways	Colour	Pair	Position	Adapter Keyways
Blue	1	1	Duplex adapter position: Keyways up (by default)	Blue	1	1	Duplex adapter position: Keyways down (to be changed on site)
Orange		2		Orange		2	
Green	2	3		Green	2	3	
Brown		4		Brown		4	
Grey	3	5		Grey	3	5	
White		6		White		6	
Red	4	7		Red	4	7	
Black		8		Black		8	
Yellow	5	9		Yellow	5	9	
Violet		10		Violet		10	
Pink	6	11		Pink	6	11	
Turquoise		12		Turquoise		12	
Blue + 1 ring	7	13		Blue + 1 ring	7	13	
Orange + 1 r.		14		Orange + 1 r.		14	
Green + 1 r.	8	15		Green + 1 r.	8	15	
Brown + 1 r.		16		Brown + 1 r.		16	
Grey + 1 r.	9	17		Grey + 1 r.	9	17	
White + 1 r.		18		White + 1 r.		18	
Blue + 2 rings	10	19		Blue + 2 rings	10	19	
Orange + 2 r.		20		Orange + 2 r.		20	
Green + 2 r.	11	21		Green + 2 r.	11	21	
Brown + 2 r.		22		Brown + 2 r.		22	
Grey + 2 r.	12	23		Grey + 2 r.	12	23	
White + 2 r.		24		White + 2 r.		24	

Table 4: Symmetrical-pair / SC connectors

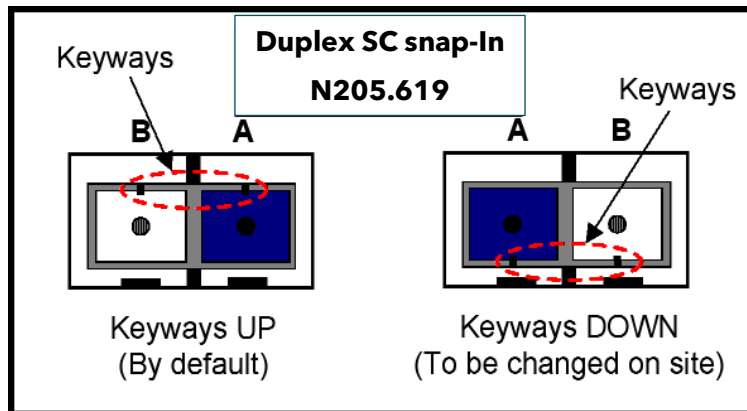

Symmetrical-pair wiring principle OF cable termination scheme							
2. Duplex LC (To be repeated twice for fully loaded patch panel)							
Campus BB: CD side				Campus BB: BD side			
Building BB: BD side				Building BB: FD side			
FTTD: FD side				FTTD: CP side (ZD box)			
Fibre coding		Patch panel		Fibre coding		Patch panel	
Colour	Pair	Position	Adapter Keyways	Colour	Pair	Position	Adapter Keyways
Blue	1	1a	Duplex adapter position: Keyways on the left side (by default)	Blue	1	1a	Duplex adapter position: Keyways on the right side (to be changed on site)
Orange		1b		Orange		1b	
Green	2	2a		Green	2	2a	
Brown		2b		Brown		2b	
Grey	3	3a		Grey	3	3a	
White		3b		White		3b	
Red	4	4a		Red	4	4a	
Black		4b		Black		4b	
Yellow	5	5a		Yellow	5	5a	
Violet		5b		Violet		5b	
Pink	6	6a		Pink	6	6a	
Turquoise		6b		Turquoise		6b	
Blue + 1 ring	7	7a		Blue + 1 ring	7	7a	
Orange + 1 r.		7b		Orange + 1 r.		7b	
Green + 1 r.	8	8a		Green + 1 r.	8	8a	
Brown + 1 r.		8b		Brown + 1 r.		8b	
Grey + 1 r.	9	9a		Grey + 1 r.	9	9a	
White + 1 r.		9b		White + 1 r.		9b	
Blue + 2 rings	10	10a		Blue + 2 rings	10	10a	
Orange + 2 r.		10b		Orange + 2 r.		10b	
Green + 2 r.	11	11a		Green + 2 r.	11	11a	
Brown + 2 r.		11b		Brown + 2 r.		11b	
Grey + 2 r.	12	12a		Grey + 2 r.	12	12a	
White + 2 r.		12b		White + 2 r.		12b	

Table 5: Symmetrical-pair / LC connectors

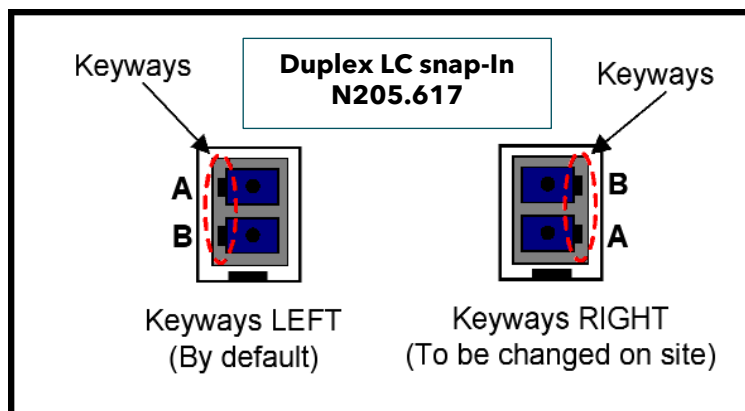

5.5 FD to TO Horizontal OF links

Dual fibre cables (Zip-cord cable / ZC) used to be installed to link the OF Telecom Outlet (TO) to the Floor Distributor (FD).

For this type of application, Aginode recommends to use the reverse-pair wiring principle when terminating the Zip-cord with the field installable connectors or when splicing the pigtails on site.

In other words, the installer will produce the equivalent of a Cross-over OF patch cord (A connected to B and B connected to A)

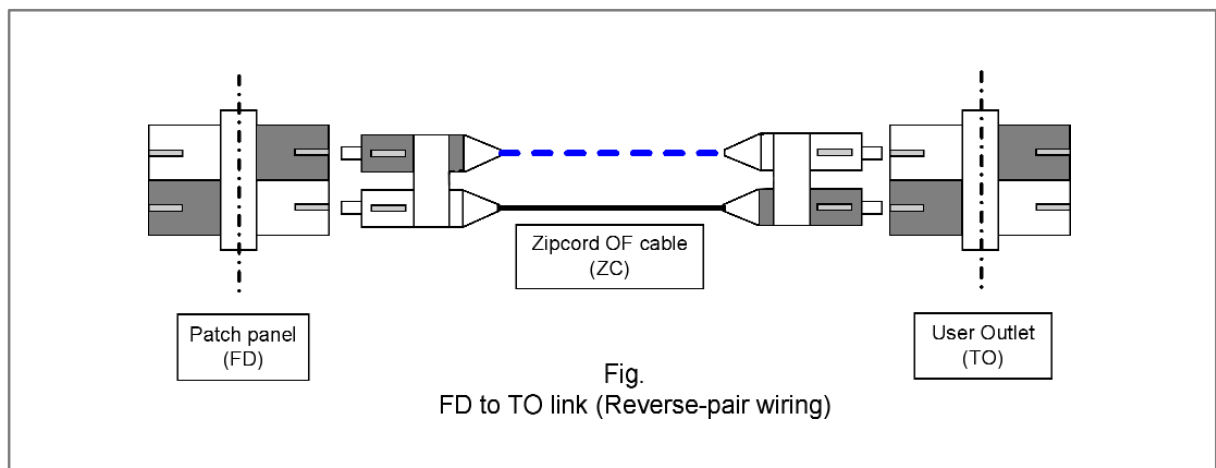

5.6 Horizontal OF links with Consolidation Point (CP)

As the Aginode ZD box (N521.610 or 630) will be used to form the Consolidation Point, up to 12 FO (SC) or 24 FO (LC) can be connected on the CP.

Therefore 12 or 24 FO cables (TBUN or MBUN cable) can be installed between the FD and the CP.

Figures 10 and 11 are showing the complete FD / CP / TO path using one or the other principle.

As for the backbone links both reverse-pair or symmetrical-pair principles can be used for the FD to CP link.

- The OF cable termination scheme from the table 2 and 3 are to be used if the reverse-pair principle is implemented (Recommended).
- The OF cable termination scheme from the table 4 and 5 are to be used if the symmetrical-pair principle is implemented.

As for the direct FD to TO link, Aginode recommends to use the reverse-pair principle.

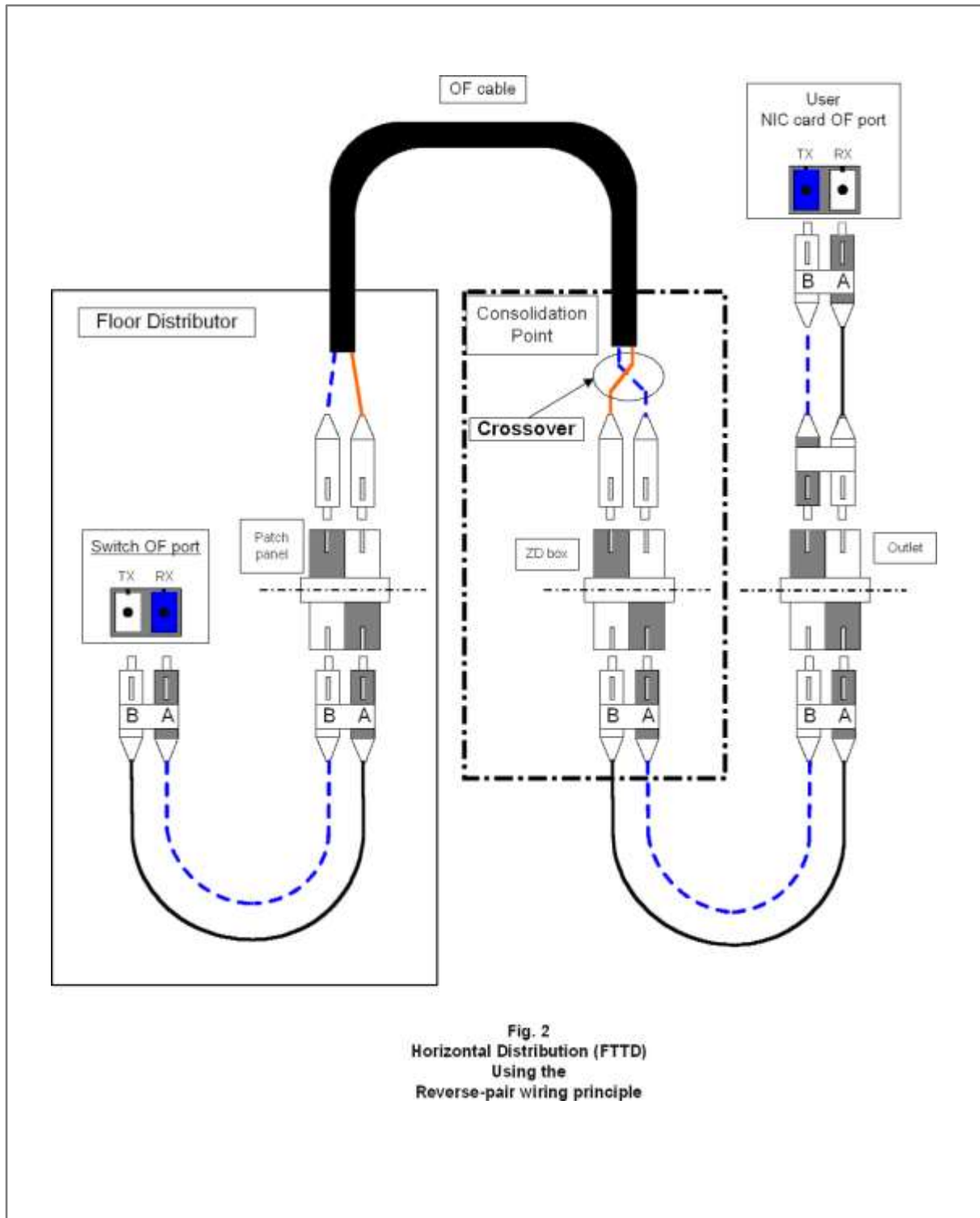

Fig. 2
Horizontal Distribution (FTTD)
Using the
Reverse-pair wiring principle

OF cable termination scheme: Refer to Table 2 and 3 from paragraph 5.4

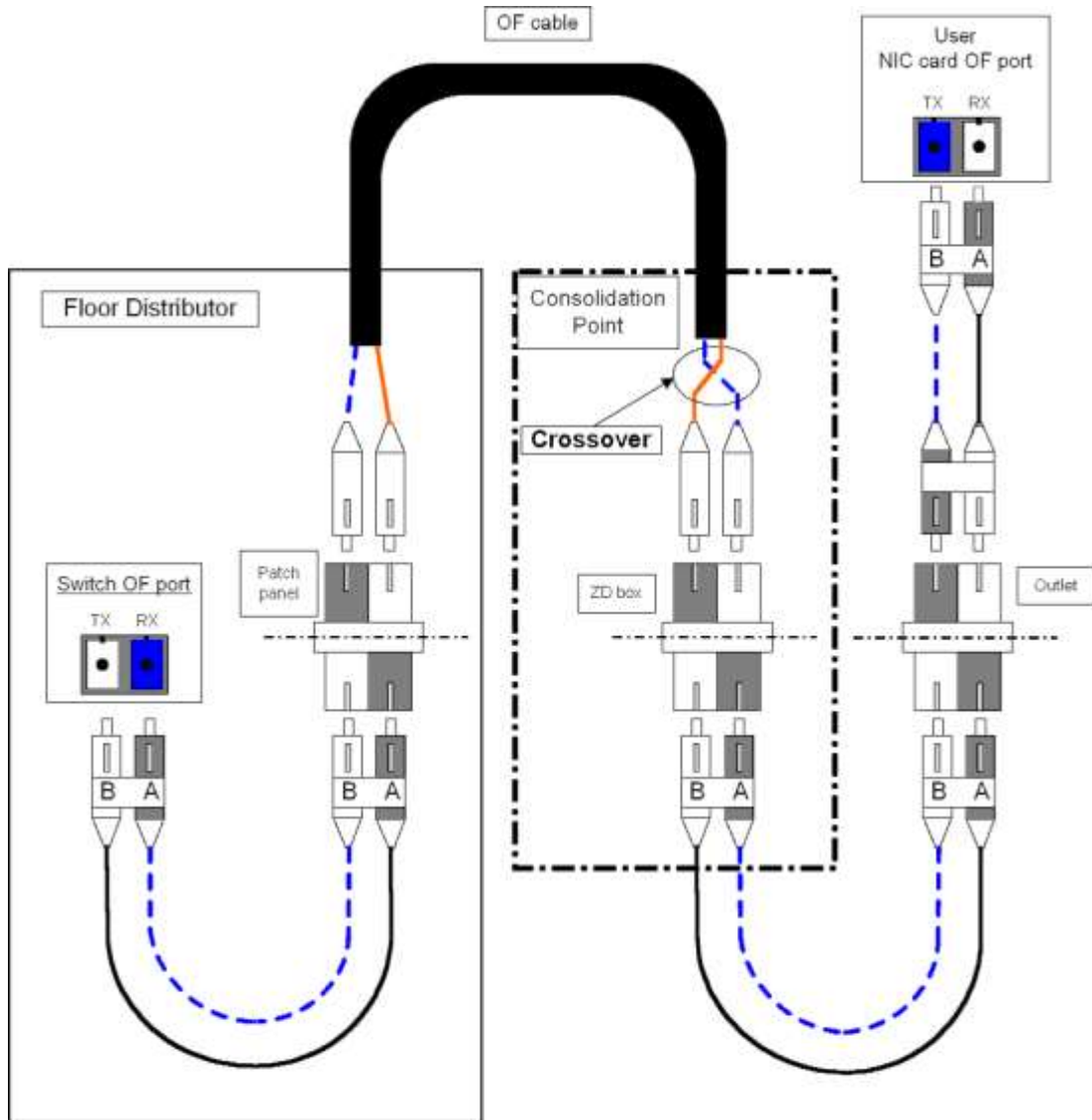

Fig. 2
Horizontal Distribution (FTTD)
Using the
Reverse-pair wiring principle

OF cable termination scheme: Refer to Table 4 and 5 from paragraph 5.4

6 Conclusions

When using standard OF cords, all Aginode cabling system designs have to take the OF channel polarity recommendations into account.

The implementation of the reverse-pair wiring principle is recommended in any case.

As a typical cabling system OF backbone is connected to the Ethernet network and so mainly require the use of duplex OF channels, the reverse-pair wiring scheme should be implemented as the default one.

Should the customer or its representative express the need for single OF channels, the reverse-pair wiring scheme can also be implemented as far as the final user accepts to have all the fibres connected on reversed positions on both ends of the links.

The symmetrical-pair wiring scheme can be implemented but is only recommended if the final user doesn't want to have fibre-pairs termination installed on reversed positions onto both ends of the link.

Aginode strongly recommends not mixing both principles within the same system (Choosing the adapted one for every link). Working on this way can only lead to mistakes and the management of the MACs (Move, Add & Changes) would become a nightmare.