

Optical Fibre Ruggedised Lockable Zone Distribution Box

PRODUCT INSTALLATION GUIDE

December 2024 - V2.0



Optical Fibre Ruggedised Lockable Zone Distribution Box PRODUCT INSTALLATION GUIDE

Product References

Description	Part Number
LANmark Ruggedised Lockable ZD Box White	N521.612
LANmark Ruggedised Lockable ZD Box Foot White	N521.6121

Document information

Release	December 2024
Published by	Aginode
Contact address	Alsembergsesteenweg 2, b3
1501 Buizingen Belgium	
Phone	+32 2 363 38 00
Website	www.aginode.net/en/
E-mail	info@aginode.net

Important Notice

The information contained in this document has been carefully checked and is assumed to be entirely correct and reliable at the time of publishing. However, Aginode reserves the right to make such changes to its products or its documentation as it deems necessary, in order to make improvements. Aginode rejects all responsibility for the use made of its products or of its documentation.

In this document, no mention is made of rights with respect to trademarks or tradenames which may attach to certain words or signs. The absence of such mention, however, in no way implies that there is no protection.

General

Installation is to be performed by qualified service personnel.

The Installation of the Ruggedised Lockable Zone Distribution box (RLZD box) must be carried out with care and precision. Preparation work should be carried out on a clean and level work-surface.

Each LANmark Ruggedised Lockable ZD Box White (N521.612) is supplied with:

- 1 RLZD box
- 1 screw and washer kit for optional splice tray fixing
- 1 key to lock the hinged lid for access to the Snap-In ports
- 1 special screwdriver bit to open and close the cabling area of the ZD box
- 1 sticker with Laser warning sign
- 1 labelling strip



Each LANmark Ruggedised Lockable ZD Box Foot White (N521.6121) is supplied with:

- 1 RLZD foot plate
- 1 screw and washer kit to fix the foot to the RLZD box

The foot has to be ordered separately

This part is designed to raise the RLZD box (N521.612) up by approximately 50mm to provide protection against water ingress from potential leaks and to aid installation.

Other ancillaries (e.g. splice trays) must also be purchased separately. The product part numbers are mentioned where applicable in the following text.



Phase 1: Preparation of the RLZD box

Open the hinged lid to gain access to the front part of the box and get the plastic bag containing the accessories.



The cover is fastened with tamper-resistant screws. Use the specific screwdriver bit located in the plastic bag to remove the top cover.

Note: The bit holder is not provided.



Phase 1: Preparation of the RLZD box

Stick the Laser warning sign on the cover
(See note 3).



Stick the labelling strip on the base in front
of the ports.



Notes

1. More specific installation guidelines on optical fibre cable can be obtained from the "Installation Guide for OF cables" document which is available from the AGINODE website.
2. The Ruggedised ZD box can be equipped with both copper and fibre Snap-Ins. Mixed copper/fibre RLZD boxes can also be created.
3. The laser warning sticker is not needed when the RLZD box is only equipped with copper cables and RJ45 connectors.

Phase 2: Fitting of the RLZD box

The RLZD box is easy to install on walls, under raised floors or in ceiling voids, due to its multiple mounting features. Use the 4 mounting holes located in the corners of the base to fix the box on walls or other locations. Fixing screws are not provided.

MOUNTING DIMENSIONS FOR N521.612 AND N521.6121

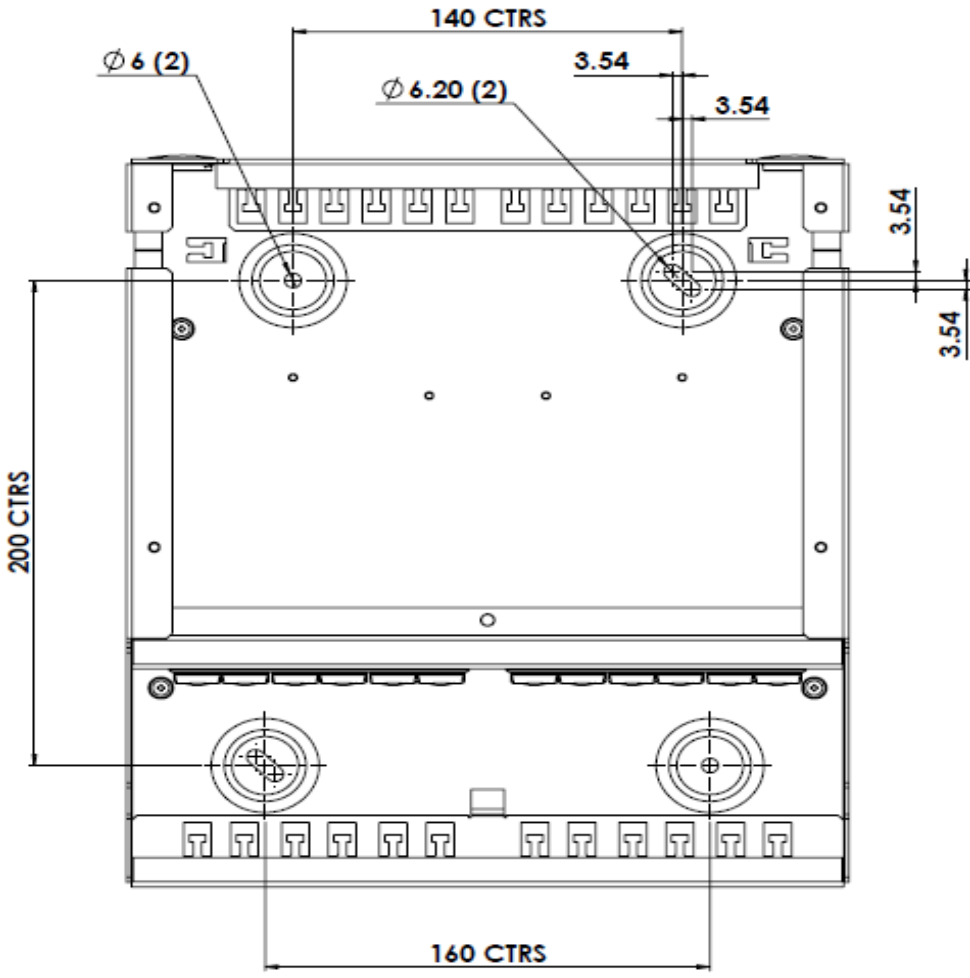

Phase 2: Fitting of the RLZD box

Alternatively the optional foot plate can be fitted to the RLZD box using the screw and washer kit provided with the foot.

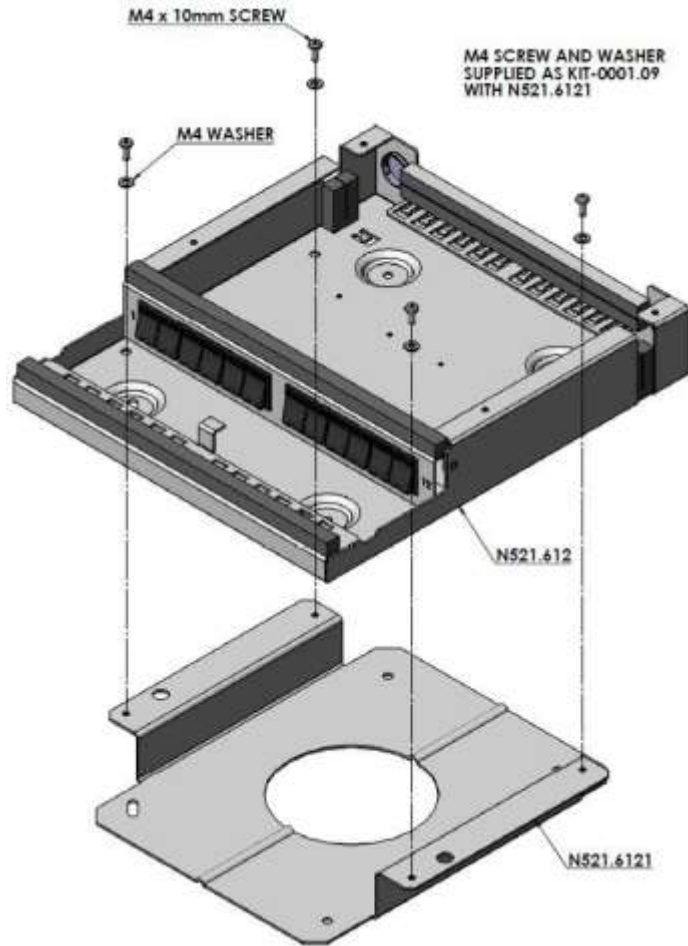

Use the 4 mounting holes present in the corners of the foot to first fix the assembly on the slab or other locations.

Note: Fixing screws are not provided. (see mounting dimensions on previous page)

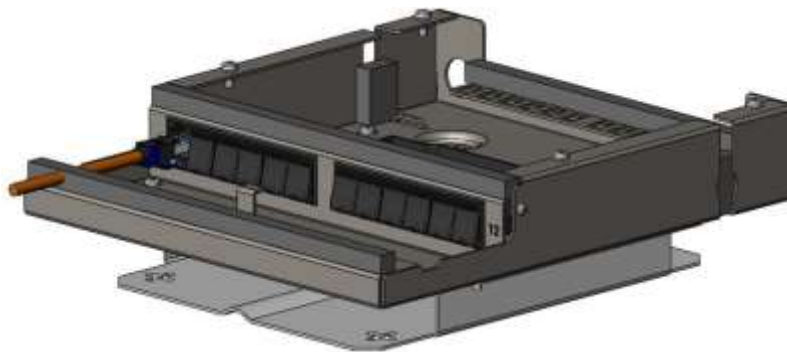

N521.6121 LANmark Ruggedised Lockable RLZD box assembled with foot plate

Phase 3: Choosing couplers and/or connector types

The advantage of the ruggedised Snap-in ZD box is the flexibility to accept different types of OF couplers and copper connectors. Three versions can be created by using the LANmark Snap-In couplers. These couplers must be purchased separately. Available optical fibre couplers are: duplex SC and duplex LC (SM and MM). Note: The RLZD box can be loaded with up to 6 duplex SC or 12 duplex LC.

Important note

Please be aware that dual patch cords terminated with duplex SC connectors are not compatible with two single SC couplers. The orientation of the key is different on SC and duplex SC Snap-In couplers.

OF couplers



- N205.617: LANmark-OF Duplex LC Snap-In Adaptor Multimode (Aqua)
- N205.627: LANmark-OF Duplex LC Snap-In Adaptor Singlemode (Blue)
- N205.628: LANmark-OF Duplex LC Snap-In Adaptor Singlemode APC (Green)



- N205.619: LANmark-OF Duplex SC Snap-In Adaptor Multimode Aqua
- N205.624: LANmark-OF Duplex SC Snap-In Adaptor Singlemode (Blue)
- N205.625: LANmark-OF Duplex SC Snap-In Adaptor Singlemode APC (Green)

Phase 3: Choosing couplers and/or connector types

Copper connectors

Note: The RLZD box can be loaded with all Snap-In copper connectors



- N420.660: LANmark-6 Evo Snap-In Connector Category 6 Unscreened
- N420.666: LANmark-6 Evo Snap-In Connector Category 6 Screened
- N420.66A: LANmark-6A Evo Snap-In Connector Category 6A 500MHz Screened
- N420.730: LANmark-7 GG45 12C Snap-In Connector Cat 7 600MHz Screened
- N420.735: LANmark-7A GG45 12C Snap-In Connector Cat 7A 1000MHz Screened

Phase 4: Installing couplers and/or connector types

The installation process is identical for both Snap-In OF couplers and Snap-In copper connector.

First remove the protective caps on the front of the OF couplers.

Snap the couplers/ connector into the ZDBox by hooking the top of the coupler under the front mounting plate and then lowering the coupler into its aperture until it is locked (you will hear a click when it is locked).

Make sure to keep the protective caps in place on the back of the couplers during installation to avoid ingress of dust. Do not remove the shutters.

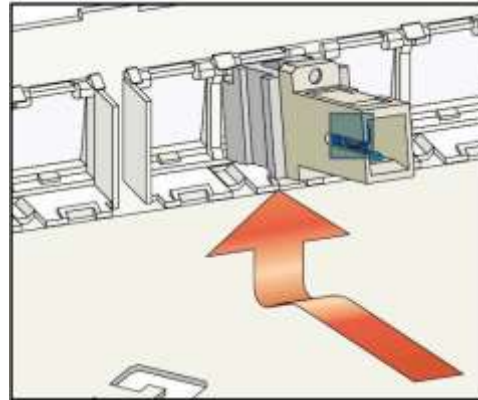

To remove a coupler or a connector, carefully insert a small screwdriver blade in the opening below it, to unlock it.

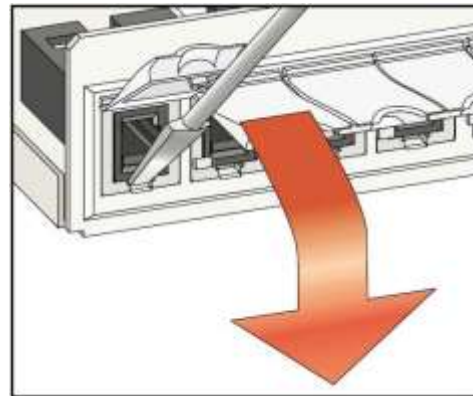

Coloured shutters for Snap-In structural hardware

The white shutters supplied with the RLZD box are removable and can be replaced with coloured versions. These shutters are available in 8 different colours.

N421.701BLA	LANmark shutter black 100 x
N421.701BLU	blue
N421.701DGR	dark grey
N421.701ORA	orange
N421.701RED	red
N421.701WHI	white
N421.701YEL	yellow
N421.701GRE	green



Phase 5: Connector Termination

Copper connector termination

EVO Snap-In copper RJ45 connectors have to be terminated before installation in the front plate of the RLZD box.

Refer to the EVO product installation sheet provided with the connectors and also available from the AGINODE web library.

Snap the connectors into the ZD box.



Secure the data copper cables using the tie wrap upstands located at the rear of the base. Ties shall not significantly deform the cable sheath - This should be hand tight.

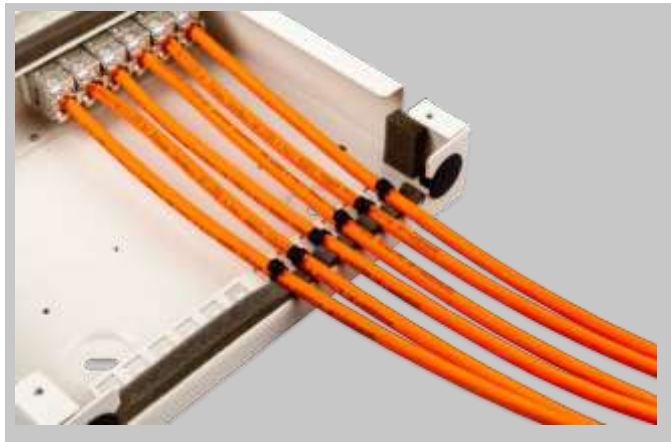

Note: Tie wraps are not provided.

Patch cords can also be secured using the front tie wrap upstands.

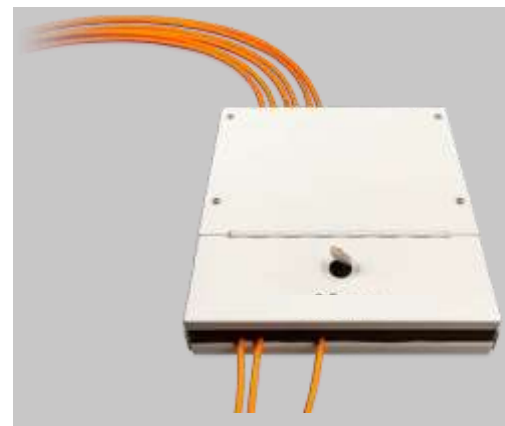
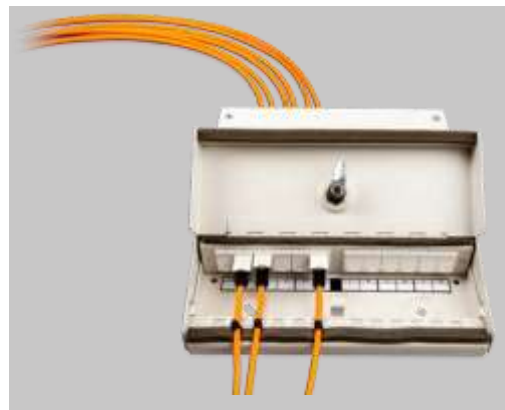

Fibre connector termination

Ensure a length of spare cable (slack) is provided. As well as being required to facilitate the termination of the cable in the RLZD box, spare cable will allow for the possibility of re-termination, repair and ability to relocate the RLZD box if required in the future.

Notes

Spare cable may require special stowage requirements in the installation. Before termination, always cut off the first meter of cable as this part can be damaged after pulling the cable, bending etc. The removal of this 1m section should be taken into consideration in respect to the final amount of cable slack provided.

1. Direct termination

This is suited primarily to Multimode fibres. Direct termination on Singlemode fibres is restricted to specific connector types (see table next page).

2. Pre-terminated solutions

This is selected for ease of installation, particularly where the following elements are determining factors:

- the installation time window is short, and /or
- where there is a large number of connectors to be installed, and/or
- where minimum link loss performance is required (see reduced loss and warranty benefits with Aginode pre-term solutions)

3. Splicing

This is suitable for both tight buffered and loose tube constructions, with appropriate use of splice protectors and splice management.

Splicing can be used to terminate standard cables or to terminate extractable-bundle cables (FTTO specific solution).

Both installation types are described in the following chapters.



LANmark-OF Microtube P/N: N890.045

LC / SC	Loose Tube / Microbundle 250µm fibres	Tight Buffer 900µm fibres
Fusion splicing MM	Yes	Yes <i>Using heat shrink splice protectors</i>
Connectorisation MM	Yes with microtube	Yes
Fusion splicing SM	Yes (preferred) <i>Using heat shrink or aluminium splice protectors</i>	Yes (preferred) <i>Using heat shrink splice protectors</i>
Connectorisation SM	Yes with microtube <i>(available but not preferred)</i>	Yes <i>(available but not preferred)</i>

Phase 5A: Termination with Direct Connectorisation

Please consult the Aginode Installation Guide For OF Cable document which is available from the AGINODE web- site. For detailed information related to the process of removal of the outer jacket, see the various supplements produced for the different cable constructions (Loose Tube, Tight Buffer or Micro Bundle).

When logged into the AGINODE site, all these documents and also others relating to design and installation testing etc. can be found [here](#)

Note: Special consideration may be required for grounding corrugated metal jacket constructions. Refer to customer / site installation specifications.

Remove approximately 2 metres of the outer sheath and the aramid/glass yarns from the cable. Avoid damaging the fibres while cutting the outer jacket and yarns. Collect all waste and dispose correctly. For 250µ fibres the tube must be removed leaving at least two loops in the loop rings. Make sure to clean the fibres (with appropriate and approved cleaning solvents) to remove the gel.

Note: A cable gland which is available separately has to be used to fix the cable to the patch panel.

20mm hole

<i>Part Number</i>	<i>Description</i>
N890.148	LANmark-OF Cable gland rubber boot 20 mm 10x

Suitable for cable diameters 4.0 – 7.8 mm



Phase 5A: Termination with Direct Connectorisation

Note: 2 fibre organisers which are available separately (bag of 10 pieces) have to be used to support the spare fibre. The screw kit is provided with the organisers.

LANmark-OF Fibre Organiser 10x (N890.070)

Install the 2 support bases using 2 small screws, washers (both locking (1) and flat (2)) from the screw kit provided with the organisers and insert 4 loop rings on every support base, with the loop ring opening facing inwards. They will be used later to support the fibres.

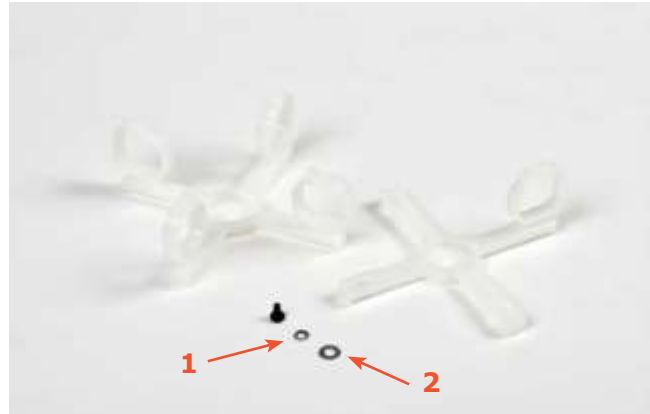

Arrows indicate fibre organisers fixing point

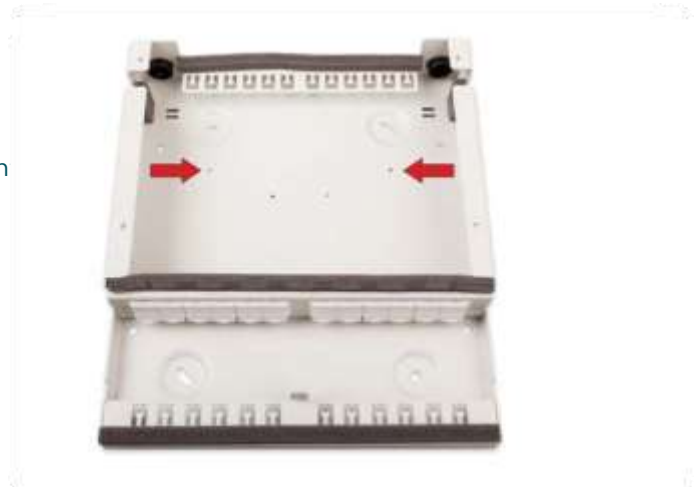

Fix the cable to the RLZD box.

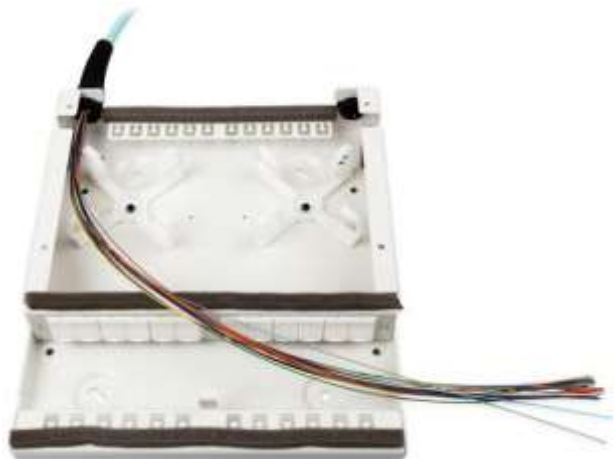

Phase 5A: Termination with Direct Connectorisation

Fix a permanent label on the fibre cable for future identification.

Provide at least 2 spare loops of core in the patch panel and locate in the loop rings.

Measure the length of each fibre core to the coupler respecting both bending radius and the color sequence, then cut off surplus and dispose of correctly.

Refer to "Recommendations to maintain OF duplex channel polarity" which is available from the AGINODE website under "File Library". Knowledge of this document content will assist in efficient preparation and storage of the cores within the rings (see annex).

Take the fibre out of the loop rings and mount the connectors on the fibre. When mounting connectors on 250 μ fibre, you will need to use microtube (N890.045) to reduce risk of damaging the fibre.

It is advisable to label the fibres for easy identification.

Labels must not compromise bend radius of the fibre cores. Remove the dust protection caps on the inside of the couplers where connectors will be inserted.

A check for the cleanliness of the couplers and of the connectors is required.

Refer to the 'OF connector Inspection cleaning and testing general guidelines' AGINODE technical paper for detailed information.

Loop the fibres back in the loop rings and insert connectors according to the colour coding / position sequence of the couplers.

Note: Always maintain installation cleanliness practice!

Close the box whenever you finish working on it and keep dust caps fitted.

Continue with Phase 6



Phase 5B: Termination with Pre-Terminated assemblies

The gland holes of the panel are open at the side and are therefore suitable for use with pre-terminated assemblies.

Note: 2 fibre organisers available separately (bag of 10 pieces) have to be used to support the spare fibre. The screw kit is provided with the organisers. LANmark-OF Fibre Organiser 10 x (N890.070)



Install the 2 support bases using 2 small screws, washers (both locking (1) and flat (2)) from the screw kit provided and insert 4 loop rings on every support base, with the loop ring opening facing inwards. They will be used later to support the fibres (see picture on page 15).



Insert the cable from the rear end of the panel. Partially remove the protective tube to access the cable gland. Slide and fasten the gland in one of the gland hole and remove the protection tube.

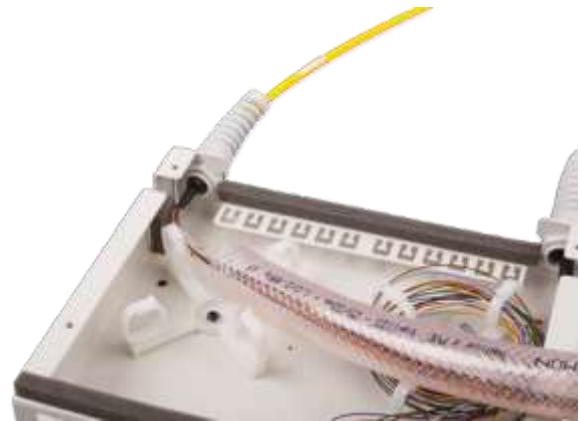

Coil the fibre using loop rings.



Phase 5B: Termination with Pre-Terminated assemblies

Remove the dust protection caps on the inside of the couplers where connectors will be inserted. A check for the cleanliness of the couplers and of the connectors is required.

Refer to the '*OF-connector Inspection cleaning and testing general guidelines*' AGINODE technical paper for detailed information.

Loop the fibres back in the loop rings and insert connectors according to the colour coding / position sequence of the couplers.



Refer to "Recommendations to maintain OF duplex channel polarity" which is available from the AGINODE website under "File Library". Knowledge of this document content will assist in efficient preparation of the cores and storing within the spindle or rings.(see Annex).

Note: Always maintain installation cleanliness practice!

Close the box whenever you finish working on it and keep dust caps fitted.

Continue with Phase 6

Phase 5C: Fibre Termination with Splicing

Please consult the Aginode Installation Guide For OF Cable document which is available from the AGINODE website. For detailed information related to the process of removal of the outer jacket, see the various supplements produced for the different cable constructions (Loose Tube, Tight Buffer or Micro Bundle).

When logged into the AGINODE site, all these documents and also others relating to design and installation testing etc. can be found there.

Note: Special consideration may be required for grounding corrugated metal jacket constructions. Refer to customer / site installation specifications.

Remove approximately 2 metres of the outer sheath and the aramid/glass yarns from the cable.

Avoid damaging the fibres while cutting the outer jacket and yarns. Collect all waste and dispose of correctly.

Install the first splice cassette on the base using the 2 screws and associated locking washers from the screw kit. Arrows indicate cassette fixing points. The additional cassettes will be installed at a later stage.

To connect the additional splice cassettes, optional hinges (N890.098) have to be fitted at the back of the splice cassettes.

Up to 2 optional splice cassettes can be installed according to the number of fibres to be terminated. With such an arrangement the additional splice cassettes can be lifted and tilted for improved access to the splices beneath them.



Phase 5C: Fibre Termination with Splicing

Splice cassettes must be ordered separately.

The splice cassette for heat shrink protection can accommodate 12 splices allowing a maximum of 24 splices per RLZD box.

- LANmark-OF Splice Cassette Heat Shrink Protections Small (N890.095)
- LANmark-OF Splice Cassette Cover Small (N890.097)
- LANmark-OF Fusion Splice Heat Shrink Protection 45 mm - 100x (N890.021)
- LANmark-OF Splice Cassette Hinges 16x (N890.098)

Note: 2 hinges are needed to connect an additional splice cassette to the first one.

Not recommended but possible:

The splice cassette for aluminium protection can accommodate 24 splices. There is no need for additional splice cassettes.

- LANmark-OF Splice Cassette Aluminum Protectors Small (N890.096)
- LANmark-OF Fusion Splice Aluminium Protection 150x (N890.003)

Note: Tool N890.004 must be used with aluminium splice protectors.

Note: N890.003 can only be used with maxistrrip pigtailed cables with 250 μ m coated fibres. The aluminium protection is not suitable for use with 900 μ m coated fibres.

For both type of splice cassette only one cover (N890.097) is required to close the last splice cassettes at the top.

An optional cable gland has to be used to secure the cable to the patch panel.

20mm hole

Part Number	Description
N890.148	LANmark-OF Cable gland rubber boot 20 mm 10x

Suitable for cable diameters 4.0 - 7.8 mm

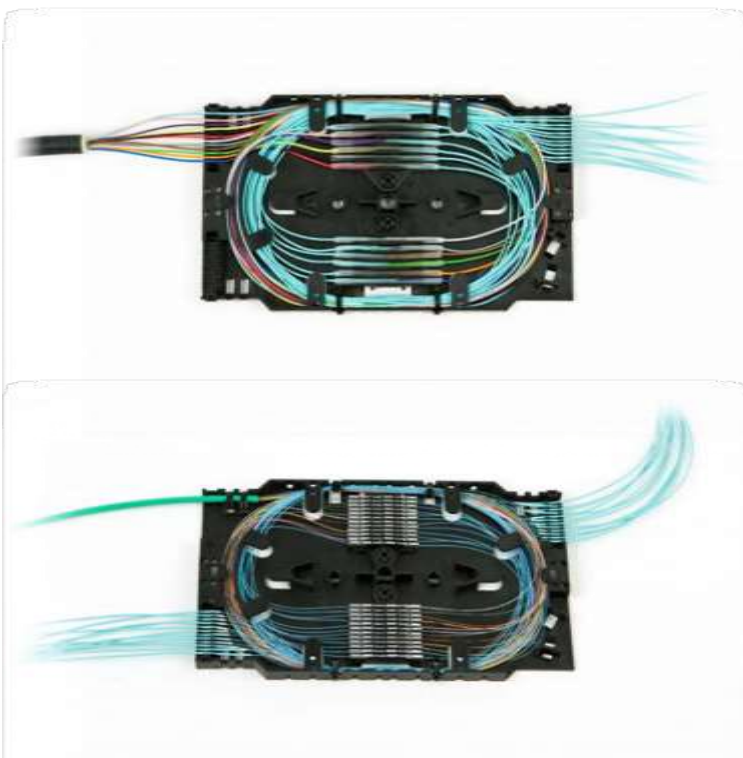

Phase 5C: Fibre Termination with Splicing

For 250 μ fibres (Loose Tube and Micro-Bundle cable structures) the tube / the bundle must be removed to expose at least two loops of slack fibres in the splice tray.

Make sure to clean the fibres (with appropriate and approved cleaning solvents) to remove the gel.

Fix the end of the remaining tube on the splice tray (A) by means of tie wraps. It is not advised to tie the tie wraps tightly as they are not used for strain relief but to keep the tube in the right position.

Do not over-tighten the tie wraps on the tube especially when working with Micro-Bundle cable.

For 900 μ m fibres (Tight Buffer cable structure) measure the length of the 900 μ buffer needed on the splice tray and fix the fibres in the comb (B) of the splice tray.

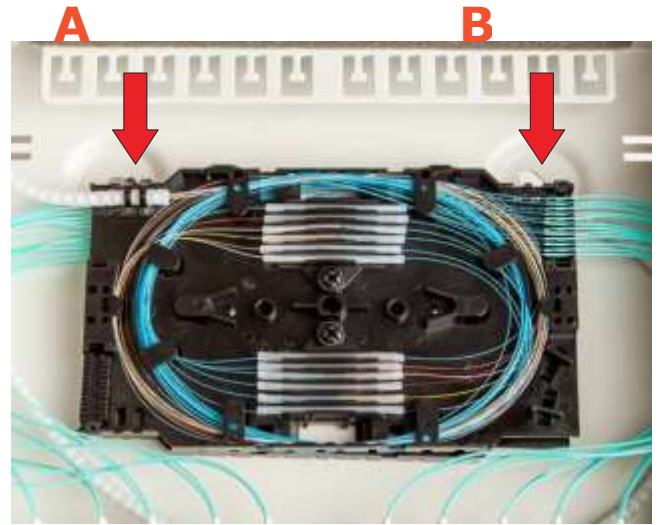

The fibres from the pigtails should make 2 loops in the opposite direction.

For 900 μ m pigtails proceed as for fibres from TB cable structure to fix the fibre on the splice tray.

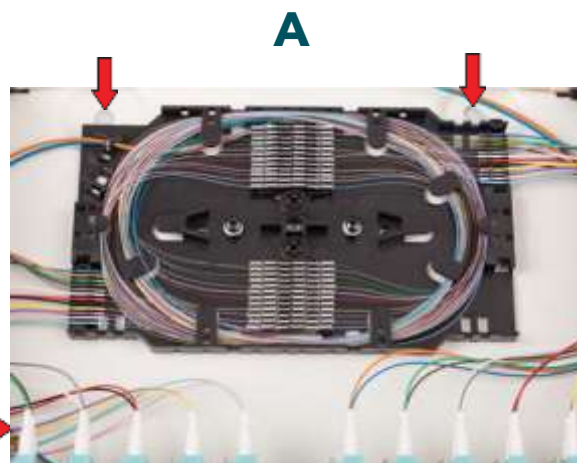

For maxi-strip pigtails, measure the length of 250 μ m buffered fibre needed on the splice tray and strip the 900 μ buffer and fix the end of 900 μ buffer in the comb (B) of the splice tray.

Phase 5C: Fibre Termination with Splicing

Slide the heat shrink protections tubes (not needed when using metallic splice protection) onto the fibres and joint them by fusion splicing with pigtails following the correct colour sequence.



It is advisable to label the fibres for easy identification. Labels must not compromise bend radius of the fibre cores.

Remove the dust protection caps on the inside of the couplers where connectors will be inserted.

A check for the cleanliness of the couplers and the connectors is required.

Refer to the 'OF connector Inspection cleaning and testing general guidelines' AGINODE technical paper for detailed information.

Insert connectors according to the colour coding position sequence of the couplers.

The "Recommendations to maintain duplex OF channel polarity" technical paper, which is available from the AGINODE website (under the File library) should be considered when choosing the colour order. (see Annex)

Continue with Phase 6

Phase 5D: Termination of Extractable-bundle Cables

Extractable-bundle cables are selected to create networks based on FTTO ring cabling topology. (see LANactive section of the AGINODE website).

Description of the extraction process

1 or 2 bundles of 12 fibres have to be extracted from the cable and be terminated in the Ruggedised Lockable Zone Distribution (RLZD) box.

First of all, the jacket of the cable has to be opened and a piece of 30 to 40 millimetres removed a few metres away from the RLZD box or in between two RLZD boxes if the same bundle will be terminated in two consecutive boxes.

The OGCL stripping tool (AGINODE part number: N890.131) shall be used to perform this task to ensure that the bundles and the fibres will not be affected by this process (see picture below).

The bundle(s) to be terminated in the RLZD box(es) will then be cut.

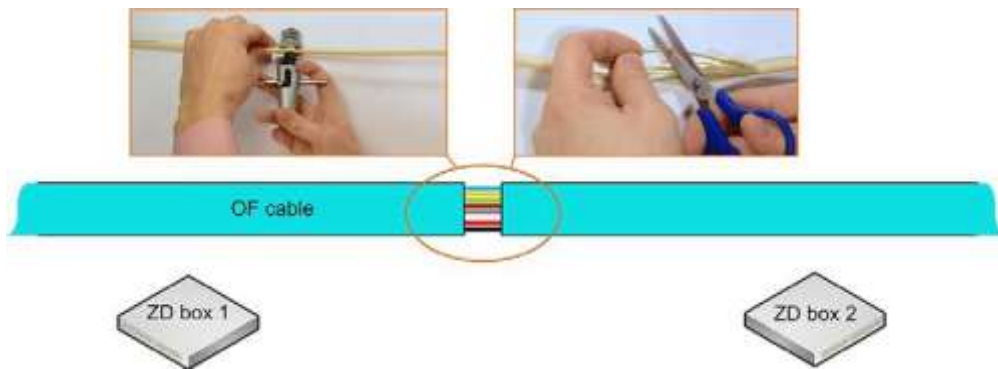

Using the same OGCL stripping tool the cable jacket will also need to be opened at the location where the RLZD box will be installed.

A piece of the jacket having the length needed to fully expose the bundle inside the RLZD box has to be removed (see detailed splicing process description page 25).

The appropriate bundle(s) will be extracted of the cable.

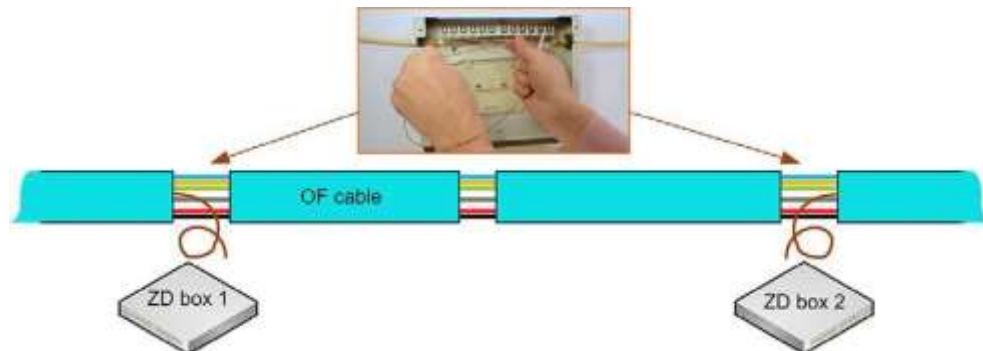

Phase 5D: Termination of Extractable-bundle Cables

The fibres will then be spliced on LC pigtailed and these will be connected to the LC adaptors in the RLZD box. Patch cords will be connected between the RLZD box and the micro-switches. The exposed bundles located between the two RLZD boxes will be covered with a cable protection box N890.170 - LANmark-OF Mini Rootfloor 5mm (see picture below).

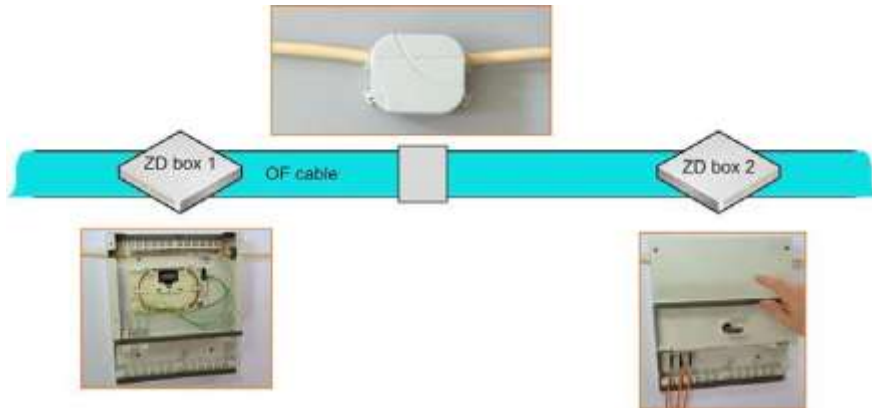

Termination process in the RLZD box

Install the first splice cassette on the base using the 2 screws and associated locking washers from the screw kit. The additional cassettes will be installed at a later stage. To connect the additional splice cassettes, optional hinges (N890.098) have to be fitted at the back of the splice cassettes. Up to 2 optional splice cassettes can be installed according to the number of fibres to be terminated. With such an arrangement the additional splice cassettes can be lifted and tilted for improved access to the splices beneath them (see picture on page 19).



Splice cassettes must be ordered separately.

The splice cassette for heat shrink protection can accommodate 12 splices allowing a maximum of 24 splices per RLZD box.

- LANmark-OF Splice Cassette Heat Shrink Protections Small (N890.095)
- LANmark-OF Splice Cassette Cover Small (N890.097)
- LANmark-OF Fusion Splice Heat Shrink Protection 45 mm - 100x (N890.021)
- LANmark-OF Splice Cassette Hinges 16x (N890.098)



Note: 2 hinges are needed to connect an additional splice cassette to the first one.

Phase 5D: Termination of Extractable-bundle Cables

Not recommended but possible:

The splice cassette for aluminium protection can accommodate 24 splices. There is therefore no need for additional splice cassettes.

- LANmark-OF Splice Cassette Aluminium Protectors Small (N890.096)
- LANmark-OF Fusion Splice Aluminium Protection 150x (N890.003)

Note: Tool N890.004 must be used with aluminium splice protectors.

Note: N890.003 can only be used with maxistrrip pigtails and cables with 250 µm coated fibres. The aluminium protection is not suitable for use with 900µm coated fibres.

For both type of splice cassette only one cover (N890.097) is required to close the last splice cassettes at the top.

Note: First cut the bundles to be terminated in the ZD box a few meters away as explained on page 23.

To remove the cable jacket use the procedure described below on a length of 30 to 40 mm.

Using the OGCL stripping tool remove the jacket of the cable on a length of 170 to 190 mm to fully expose the bundle inside the RLZD box.

1. Mark the location of the piece of cable to be remove on the cable jacket.

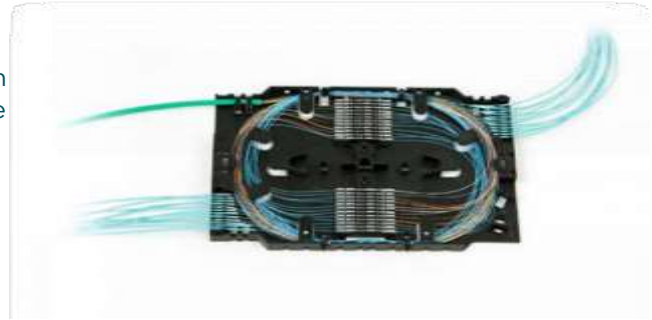

24 x aluminium protectors



Phase 5D: Termination of Extractable-bundle Cables

2. Adjust the blade of the tool according to the thickness of the cable sheath.

We recommend first testing the tool setting on a spare piece of cable.



3. Set the tool in longitudinal cutting mode using D (pull + turn).

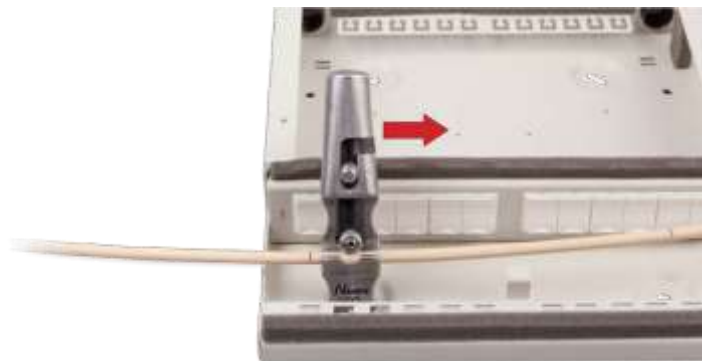
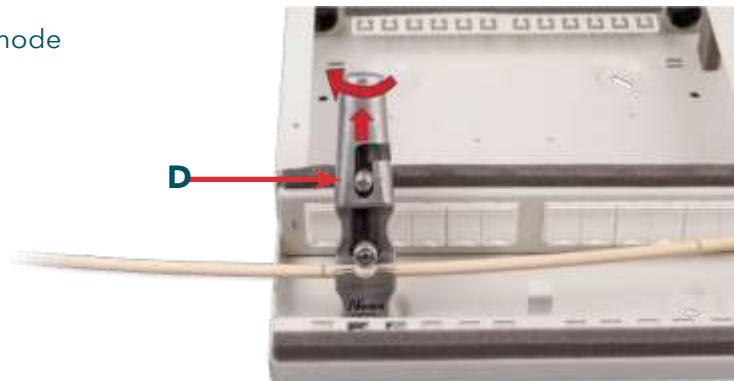

Phase 5D: Termination of Extractable-bundle Cables

4. Cut the jacket longitudinally between the two marks using the part of the tool dedicated to this operation.

Note: the blade first has to be set into the right position to adjust the penetration into the jacket and then locked using E.

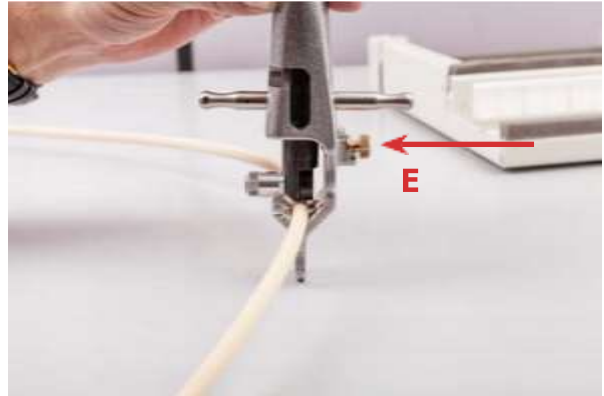

5. Set the tool in the circular cutting mode using D (pull + turn).

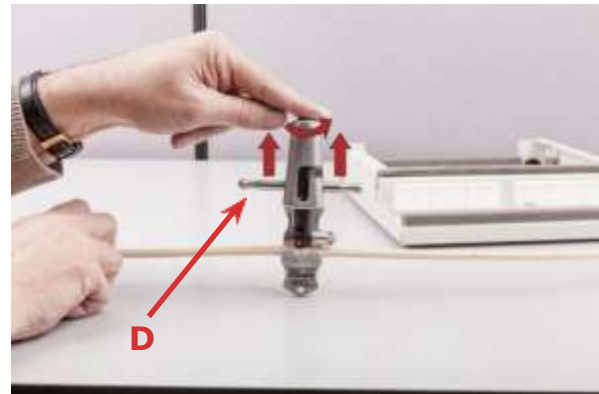

6. Place the tool on the cable with the blade located at the end of the longitudinal cut (on the first mark) and rotate the tool around the cable to cut the jacket.



Phase 5D: Termination of Extractable-bundle Cables

7. Repeat the process to cut the jacket at the other end of the longitudinal cut (on the second mark).

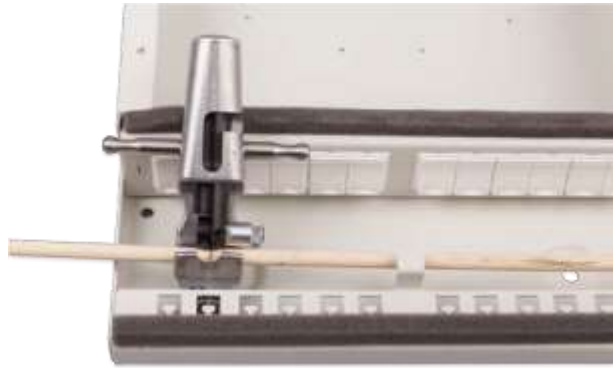

8. Gently remove the jacket.



Phase 5D: Termination of Extractable-bundle Cables

Install the cable in the RLZD box and fix it on both sides using tie-wraps as shown on the following picture

Do not over-tighten the tie wraps.



Pull the appropriate bundle(s) out of the cable

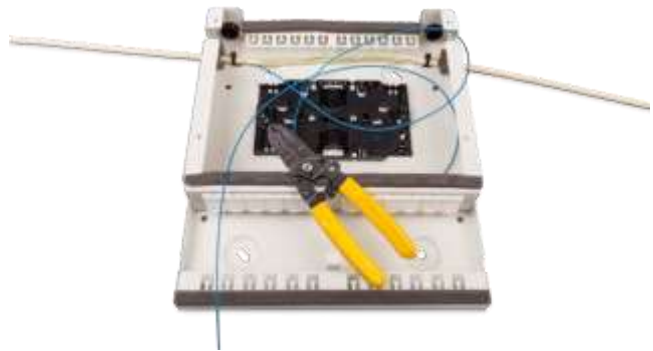

Guide the bundle(s) to the splice tray leaving at least one loop of slack bundle around the tray and cut off the surplus length leaving at least two loops of slack fibres in the splice tray.

Strip the bundle using the appropriate tool ((Multi- Wire stripper 821 - Ripley / Miller or equivalent).

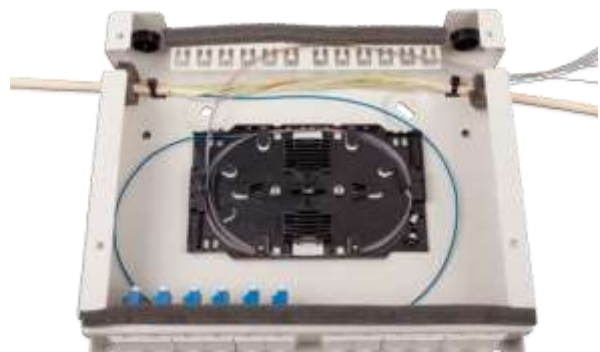

Phase 5D: Termination of Extractable-bundle Cables

Make sure to clean the fibres (with appropriate and approved cleaning solvents) to remove the gel (see Micro Bundle supplement of the Aginode Installation Guide).

Fix the end of the remaining bundle on the splice tray (A) by means of tie wraps. It is not advised to tie the tie wraps tightly as they are not used for strain relief but to keep the bundle in the right position (see page 21). Do not over-tighten the tie wraps on the bundle/tube.

The fibres from the pigtails should make 2 loops in the opposite direction.

For 900µm pigtails measure the length of the 900µm buffer needed on the splice tray and fix the fibres in the comb (B) of the splice tray.



A

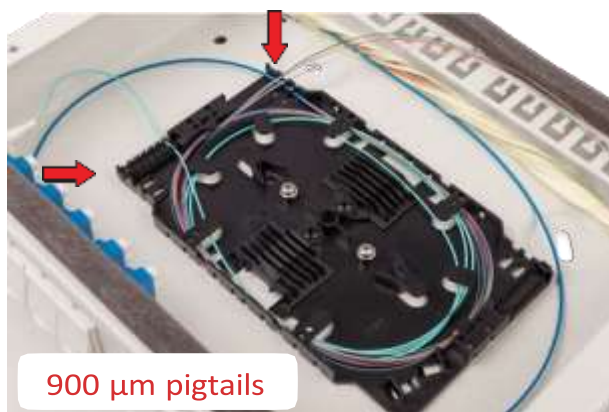

900 µm pigtails

For maxi-strip pigtails measure the length of 250µm buffered fibre needed on the splice tray and strip the 900µm buffer and fix the end of 900µm buffer in the comb (B) of the splice tray.

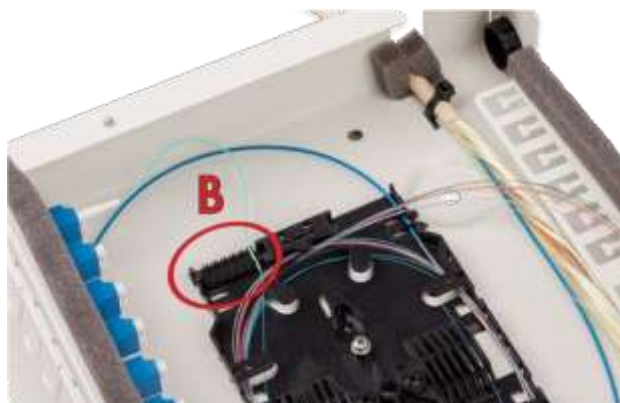

B

Phase 5D: Termination of Extractable-bundle Cables

Slide the heat shrink protection tubes (not needed when using metallic splice protection) onto the fibres and joint them by fusion splicing with pigtailed following the correct colour sequence.

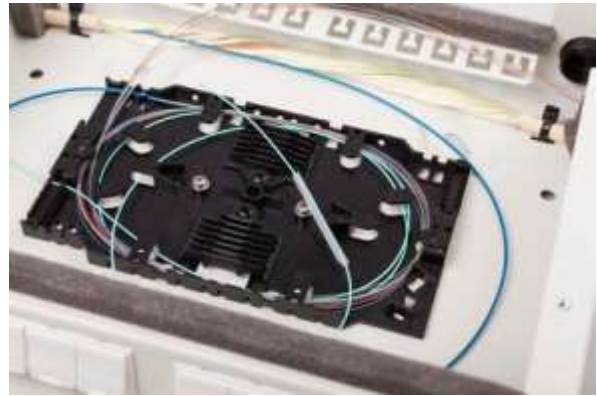

It is advisable to label the fibres for easy identification. Labels must not compromise bend radius of the fibre cores. Remove the dust protection caps on the inside of the couplers where connectors will be inserted.

A check for the cleanliness of the couplers and of the connectors is required. Refer to the 'OF connector Inspection cleaning and testing general guidelines' AGINODE technical paper for detailed information.

Insert connectors according to the colour coding / position sequence of the couplers.

The "Recommendations to maintain duplex OF channel polarity" technical paper, which is available from the AGINODE website (under the File library) should be considered when choosing the colour order. (See Annex)

Continue with Phase 6

Phase 6: Finalisation of the installation

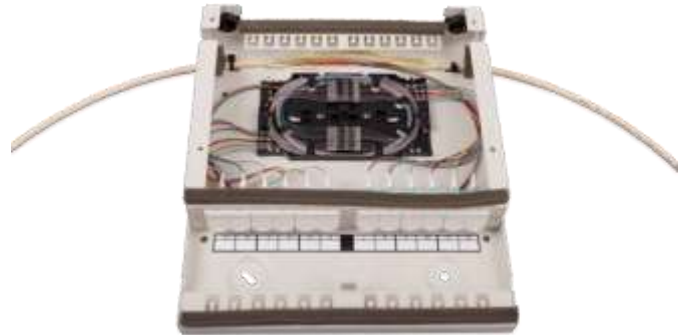

The RLZD Box can now be gently closed. Fix the top lid with the 4 screws on the top. Loop the extra fibre cable back in a safe place while respecting minimum bending radius. Label the ports to conform with the installation requirements.



Phase 6: Finalisation of the installation

The RLZD Box installation is now completed.

Do not remove the closed shutters on the front plate of the RLZD Box because they prevent ingress of dirt into the couplers.
To connect patch cords open the front lid and connect the cords.
It is recommended to fix it using tie wraps as shown.

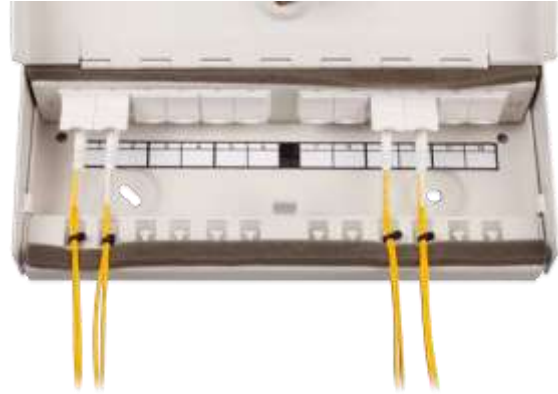

Close and lock the lid.



Annex A

IMPORTANT NOTE - INSPECTION, CLEANING & TESTING

The inspection and appropriate cleaning of all the optical fibre connectors (pigtailed, patch cords etc) prior to mating is a critical process that needs to be followed at all times.

Latest applications have stringent link loss requirements and in order to ensure that the required performance levels are achieved during commissioning and operation, the cleanliness of all fibre interfaces needs to be maintained.

The Aginode **OF connector Inspection, Cleaning & Testing general guidelines** can be downloaded from the Aginode website.

In addition, there is also a General Installation guide (for both copper and fibre) which includes further information.

Please note: The Aginode warranty may be invalidated if the cables have not been properly stored or handled according to Aginode requirements.

When logged into the Aginode site, all these documents and also others relating to design and installation testing etc can be found [here](#).

In addition, there is also a General Installation guide (for both copper and fibre) which includes further information.

Please note: *The Aginode warranty may be invalidated if the cables have not been properly stored or handled according to Aginode requirements.*

Annex B

OF system polarity

The only way to automatically maintain the duplex polarity without having to think about it, is to include a crossover into all the OF link segments.

In other words, fibres pairs have to be swapped over (interchanged) into the patch panel on one side of every link segment.

Side A			Side B		
Port Number	Fibre Number	Colour of the fibre	Colour of the fibre	Fibre Number	Port Number
1	1	Blue	Orange	2	1
2	2	Orange	Blue	1	2
3	3	Green	Brown	4	3
4	4	Brown	Green	3	4
5	5	Grey	White	6	5
6	6	White	Grey	5	6
7	7	Red	Black	8	7
8	8	Black	Red	7	8
9	9	Yellow	Violet	10	9
10	10	Violet	Yellow	9	10
11	11	Pink	Aqua	12	11
12	12	Aqua	Pink	11	12

To be repeated 2 or 4 times for a fully loaded patch panel (24 or 48 fibres)

LC pre-terminated assemblies

The connectors of the 900 µm pre-terminated assemblies are loaded with coloured boots as shown on the pictures (i.e. page 11).

The insertion has to be realised according to the colour coding sequence of the boots and NOT according to the colour of the fibres.

Indeed, the colours of the boots are swapped over at one end of the pre-terminated assembly to facilitate error free implementation of the required fibre pair-flip.

Side A				Side B			
Port Number	Fibre Number	Colour of the boot	Colour of the fibre	Colour of the fibre	Colour of the boot	Fibre Number	Port Number
1	1	Blue	Blue	Orange	Blue	2	1
2	2	Orange	Orange	Blue	Orange	1	2
3	3	Green	Green	Brown	Green	4	3
4	4	Brown	Brown	Green	Brown	3	4
5	5	Grey	Grey	White	Grey	6	5
6	6	White	White	Grey	White	5	6
7	7	Red	Red	Black	Red	8	7
8	8	Black	Black	Red	Black	7	8
9	9	Yellow	Yellow	Violet	Yellow	10	9
10	10	Violet	Violet	Yellow	Violet	9	10
11	11	Pink	Pink	Aqua	Pink	12	11
12	12	Aqua	Aqua	Pink	Aqua	11	12

Testing recommendations

Each pre-terminated assembly is 100% factory tested and a test report is always included in the packaging.

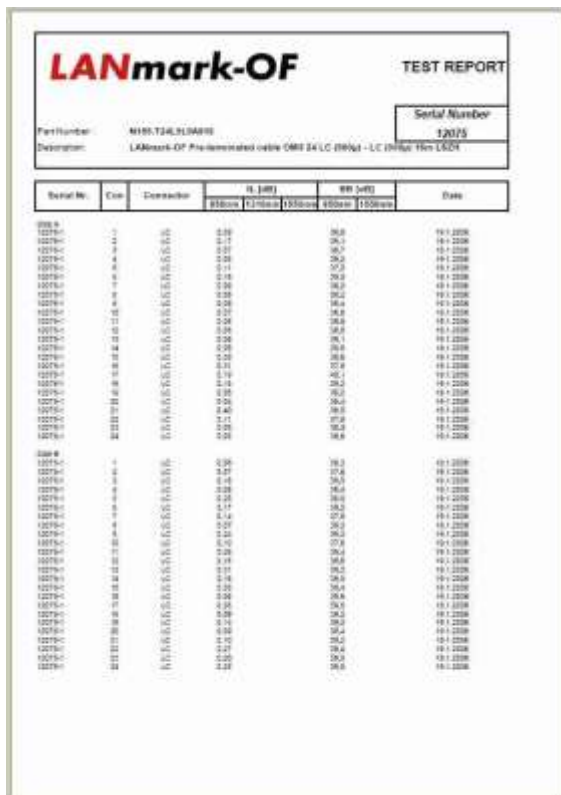

		0.1dB					0.5dB					Date
Serial No.	Core	Connector	Return Loss	Insertion Loss	Return Loss	Insertion Loss	Return Loss	Insertion Loss	Return Loss	Insertion Loss		
12278-1	2	FC/PC	0.20	0.10	0.10	0.10	0.10	0.10	0.10	0.10	19.1.2018	
12278-2	2	FC/PC	0.17	0.10	0.10	0.10	0.10	0.10	0.10	0.10	19.1.2018	
12278-3	2	FC/PC	0.20	0.10	0.10	0.10	0.10	0.10	0.10	0.10	19.1.2018	
12278-4	2	FC/PC	0.17	0.10	0.10	0.10	0.10	0.10	0.10	0.10	19.1.2018	
12278-5	2	FC/PC	0.17	0.10	0.10	0.10	0.10	0.10	0.10	0.10	19.1.2018	
12278-6	2	FC/PC	0.17	0.10	0.10	0.10	0.10	0.10	0.10	0.10	19.1.2018	
12278-7	2	FC/PC	0.17	0.10	0.10	0.10	0.10	0.10	0.10	0.10	19.1.2018	
12278-8	2	FC/PC	0.17	0.10	0.10	0.10	0.10	0.10	0.10	0.10	19.1.2018	
12278-9	2	FC/PC	0.17	0.10	0.10	0.10	0.10	0.10	0.10	0.10	19.1.2018	
12278-10	2	FC/PC	0.17	0.10	0.10	0.10	0.10	0.10	0.10	0.10	19.1.2018	
12278-11	2	FC/PC	0.17	0.10	0.10	0.10	0.10	0.10	0.10	0.10	19.1.2018	
12278-12	2	FC/PC	0.17	0.10	0.10	0.10	0.10	0.10	0.10	0.10	19.1.2018	
12278-13	2	FC/PC	0.17	0.10	0.10	0.10	0.10	0.10	0.10	0.10	19.1.2018	
12278-14	2	FC/PC	0.17	0.10	0.10	0.10	0.10	0.10	0.10	0.10	19.1.2018	
12278-15	2	FC/PC	0.17	0.10	0.10	0.10	0.10	0.10	0.10	0.10	19.1.2018	
12278-16	2	FC/PC	0.17	0.10	0.10	0.10	0.10	0.10	0.10	0.10	19.1.2018	
12278-17	2	FC/PC	0.17	0.10	0.10	0.10	0.10	0.10	0.10	0.10	19.1.2018	
12278-18	2	FC/PC	0.17	0.10	0.10	0.10	0.10	0.10	0.10	0.10	19.1.2018	
12278-19	2	FC/PC	0.17	0.10	0.10	0.10	0.10	0.10	0.10	0.10	19.1.2018	
12278-20	2	FC/PC	0.17	0.10	0.10	0.10	0.10	0.10	0.10	0.10	19.1.2018	
12278-21	2	FC/PC	0.17	0.10	0.10	0.10	0.10	0.10	0.10	0.10	19.1.2018	
12278-22	2	FC/PC	0.17	0.10	0.10	0.10	0.10	0.10	0.10	0.10	19.1.2018	
12278-23	2	FC/PC	0.17	0.10	0.10	0.10	0.10	0.10	0.10	0.10	19.1.2018	
12278-24	2	FC/PC	0.17	0.10	0.10	0.10	0.10	0.10	0.10	0.10	19.1.2018	
12278-25	2	FC/PC	0.17	0.10	0.10	0.10	0.10	0.10	0.10	0.10	19.1.2018	
12278-26	2	FC/PC	0.17	0.10	0.10	0.10	0.10	0.10	0.10	0.10	19.1.2018	
12278-27	2	FC/PC	0.17	0.10	0.10	0.10	0.10	0.10	0.10	0.10	19.1.2018	
12278-28	2	FC/PC	0.17	0.10	0.10	0.10	0.10	0.10	0.10	0.10	19.1.2018	
12278-29	2	FC/PC	0.17	0.10	0.10	0.10	0.10	0.10	0.10	0.10	19.1.2018	
12278-30	2	FC/PC	0.17	0.10	0.10	0.10	0.10	0.10	0.10	0.10	19.1.2018	
12278-31	2	FC/PC	0.17	0.10	0.10	0.10	0.10	0.10	0.10	0.10	19.1.2018	
12278-32	2	FC/PC	0.17	0.10	0.10	0.10	0.10	0.10	0.10	0.10	19.1.2018	
12278-33	2	FC/PC	0.17	0.10	0.10	0.10	0.10	0.10	0.10	0.10	19.1.2018	
12278-34	2	FC/PC	0.17	0.10	0.10	0.10	0.10	0.10	0.10	0.10	19.1.2018	
12278-35	2	FC/PC	0.17	0.10	0.10	0.10	0.10	0.10	0.10	0.10	19.1.2018	
12278-36	2	FC/PC	0.17	0.10	0.10	0.10	0.10	0.10	0.10	0.10	19.1.2018	
12278-37	2	FC/PC	0.17	0.10	0.10	0.10	0.10	0.10	0.10	0.10	19.1.2018	
12278-38	2	FC/PC	0.17	0.10	0.10	0.10	0.10	0.10	0.10	0.10	19.1.2018	
12278-39	2	FC/PC	0.17	0.10	0.10	0.10	0.10	0.10	0.10	0.10	19.1.2018	
12278-40	2	FC/PC	0.17	0.10	0.10	0.10	0.10	0.10	0.10	0.10	19.1.2018	
12278-41	2	FC/PC	0.17	0.10	0.10	0.10	0.10	0.10	0.10	0.10	19.1.2018	
12278-42	2	FC/PC	0.17	0.10	0.10	0.10	0.10	0.10	0.10	0.10	19.1.2018	
12278-43	2	FC/PC	0.17	0.10	0.10	0.10	0.10	0.10	0.10	0.10	19.1.2018	
12278-44	2	FC/PC	0.17	0.10	0.10	0.10	0.10	0.10	0.10	0.10	19.1.2018	
12278-45	2	FC/PC	0.17	0.10	0.10	0.10	0.10	0.10	0.10	0.10	19.1.2018	
12278-46	2	FC/PC	0.17	0.10	0.10	0.10	0.10	0.10	0.10	0.10	19.1.2018	
12278-47	2	FC/PC	0.17	0.10	0.10	0.10	0.10	0.10	0.10	0.10	19.1.2018	
12278-48	2	FC/PC	0.17	0.10	0.10	0.10	0.10	0.10	0.10	0.10	19.1.2018	
12278-49	2	FC/PC	0.17	0.10	0.10	0.10	0.10	0.10	0.10	0.10	19.1.2018	
12278-50	2	FC/PC	0.17	0.10	0.10	0.10	0.10	0.10	0.10	0.10	19.1.2018	

However, all fibres should be tested to ensure that the fibres and the connectors have not been affected by the installation process.

It will also ensure that

- the system polarity has been correctly managed
- all the connectors are clean

Note: if the Aginode 25-year system warranty is required, testing and submission of results for certification is a mandatory requirement.

Testing has to be performed according to the Aginode OF field testing procedure which is available from our website.

Annex C
End of life management

4. INSTRUCTIONS DE FIN DE VIE
END LIFE INSTRUCTIONS

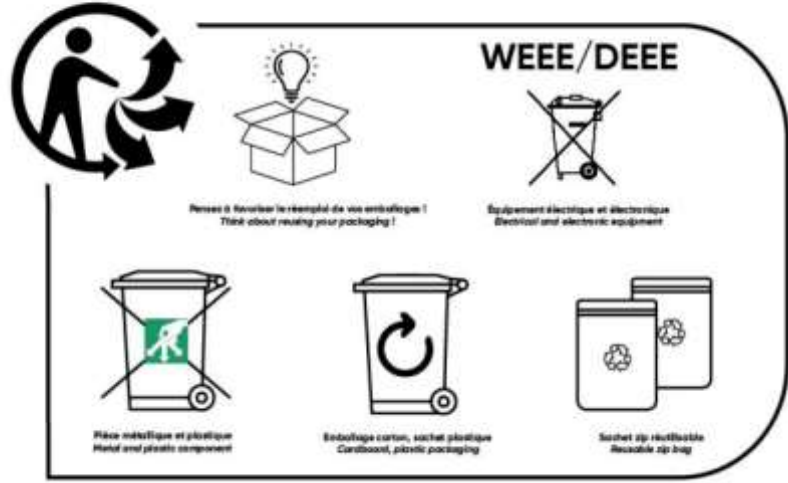

Disclaimer

This document is a guideline only. International and local procedures and safety standards must be observed and followed at all times.

Aginode will not be held liable for any damage or injury to personnel, equipment or business directly or indirectly as a result of using this document in part or in whole.

The practices contained herein are designed as a guide for use by persons having the required technical skill at their own discretion and risk. The recommended practices are based on average conditions. Aginode does not guarantee any favourable results or assume any liability in connection with this document.

Aginode does not assume any responsibility for the accuracy or completeness of this document.

The user should review the information to ensure conformity to the current applicable codes and regulations and to the project requirements.

Aginode reserves the right to change the technical specifications at any time without notice.

Edition 18.12.2024

Copyright © Aginode 2024

All data subject to change
without prior notice.