

Document : ABS1594/B
Date : 22/01/2024

#smartconnection

NOTICE / INSTRUCTIONS



@XS-OUTLET FAST

Prise Optique 1 ou 2 FO
Optical Outlet 1 or 2 OF

www.aginode.net



Table des matières

Table of contents

| | |
|--|-----------|
| 1. DESCRIPTION | |
| OVERVIEW | 4 |
| 1.1. PRÉSENTATION DU PRODUIT | |
| PRODUCT PRESENTATION..... | 4 |
| 1.2. CARACTÉRISTIQUES TECHNIQUES | |
| TECHNICAL CHARACTERISTICS..... | 5 |
| 1.3. KITS FOURNIS | |
| PROVIDED KITS..... | 5 |
| 2. OPÉRATIONS PRÉLIMINAIRES | |
| PRELIMINARY OPERATIONS | 6 |
| 2.1. FIXATION DE LA PLATINE | |
| PLATE INSTALLATION..... | 6 |
| 2.2. FIXATION SANS LA PLATINE | |
| FIXATION WITHOUT THE PLATINE..... | 7 |
| 3. INSTALLATION D'UN CÂBLE | |
| CABLE INSTALLATION | 8 |
| 3.1. PRÉPARATION DU CÂBLE | |
| CABLE PREPARATION..... | 8 |
| 2.3. OUVERTURE DE LA PRISE | |
| OPENING THE OUTLET..... | 8 |
| 3.2. INSTALLATION DU CÂBLE | |
| CABLE INSTALLATION..... | 9 |
| 4. ÉPISSURAGE DES FIBRES | |
| FIBRES SPLICING | 10 |
| 5. FINALISATION DE L'INSTALLATION | |
| FINALISING THE INSTALLATION | 11 |
| 6. RACCOREMENT DU CLIENT | |
| CONNECTING THE SUBSCRIBER | 11 |
| 7. INSTRUCTIONS DE FIN DE VIE | |
| END LIFE INSTRUCTIONS | 12 |

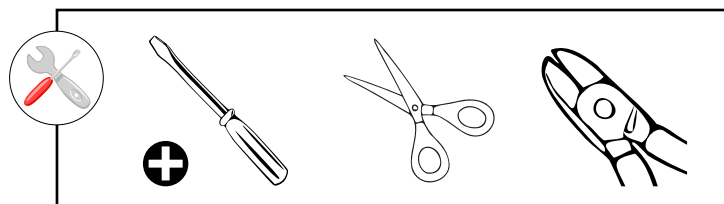

1. DESCRIPTION OVERVIEW

1.1. Présentation du produit *Product presentation*

| | | | |
|----|---------------------------------------|----|--|
| 1- | Capot de protection | 1- | <i>Protective cover</i> |
| 2- | Raccords à clapet interne SC | 2- | <i>SC internal shutter adaptor</i> |
| 3- | Supports pour épissures | 3- | <i>Splicing holders</i> |
| 4- | Adaptateur pour fixation sur rain DIN | 4- | <i>An adapter for mounting on DIN rail</i> |
| 5- | Platine de fixation | 5- | <i>Fixation plate</i> |
| 6- | Corps | 6- | <i>Base</i> |
| 7- | Zone de lovage | 7- | <i>Coiling area</i> |

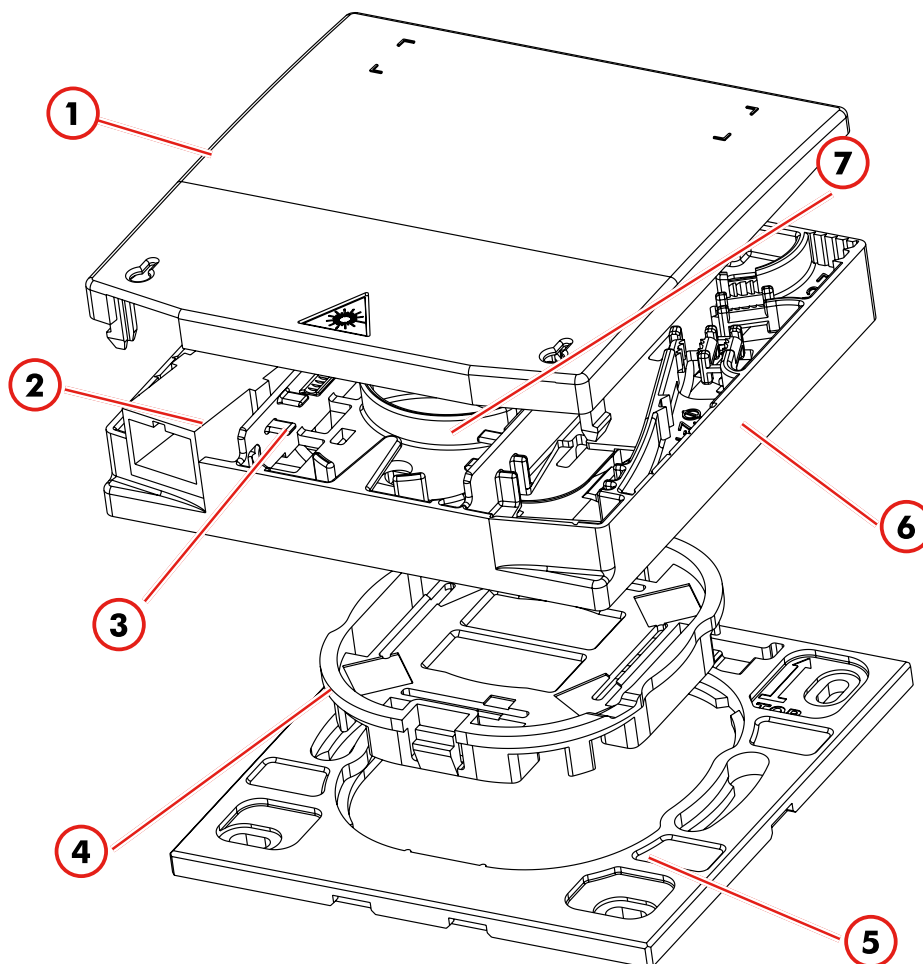

Une zone d'identification est prévue sur le capot de protection.

An identification area is provided on the protective cover.

1.2. Caractéristiques techniques
Technical characteristics

- | | | | |
|----------------|---------|-----------|--------|
| - Hauteur : | 80 mm | - Height: | 80 mm |
| - Largeur : | 80 mm | - Width: | 80 mm |
| - Profondeur : | 18,5 mm | - Depth: | 18.5mm |

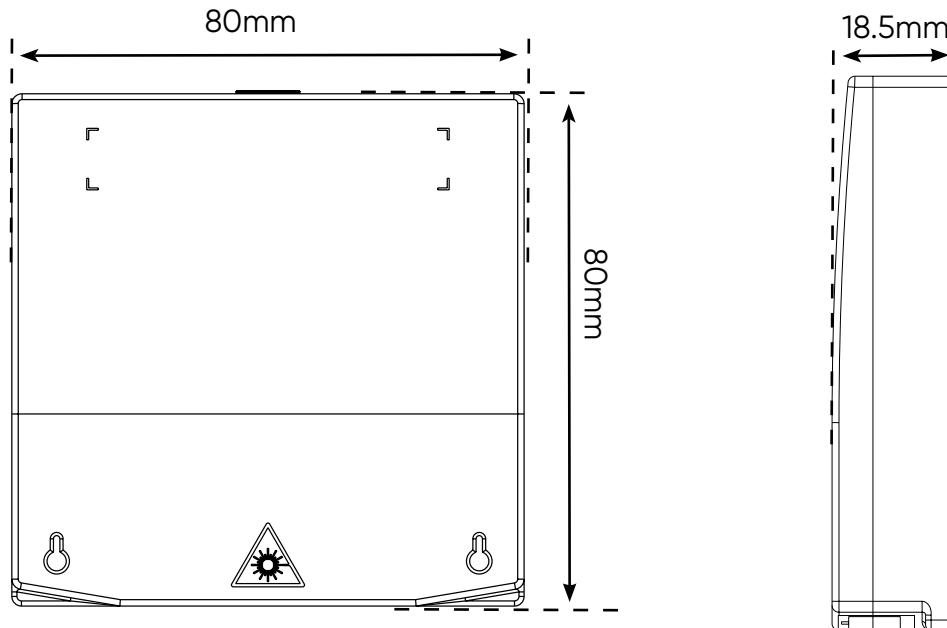

1.3. Kits fournis
Provided kits

| Description | | Qté / Qty |
|-------------------|----------------------|-----------|
| Kit de fixation: | <i>Fixation kit:</i> | |
| - Vis | - Screws | 2 |
| - Chevilles | - Anchors | 2 |
| Collier plastique | Plastic tie | 1 |

2. OPÉRATIONS PRÉLIMINAIRES PRELIMINARY OPERATIONS

2.1. Fixation de la platine Plate installation



Orientation de la platine.



Plate orientation.

La flèche indique le **haut** de la prise.
The arrow shows the **upper side** of the outlet.

2.1.1. Par collage Using tape

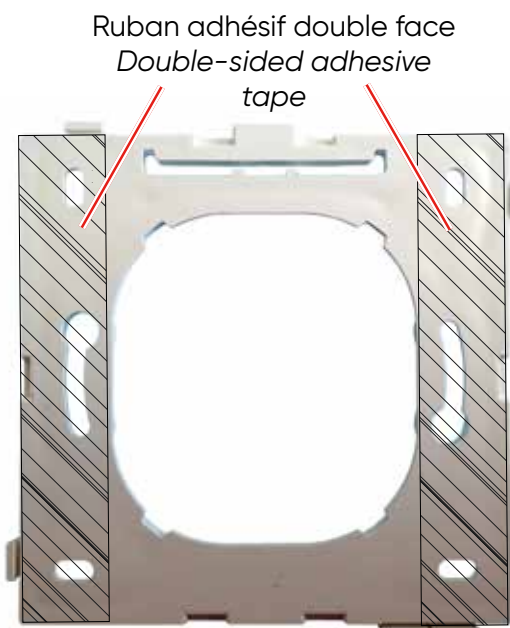

2.1.2. Par vissage au mur Wall mounting with screws



Privilégier le collage lorsque cela est possible.
Prefer wall mounting using tape whenever possible.

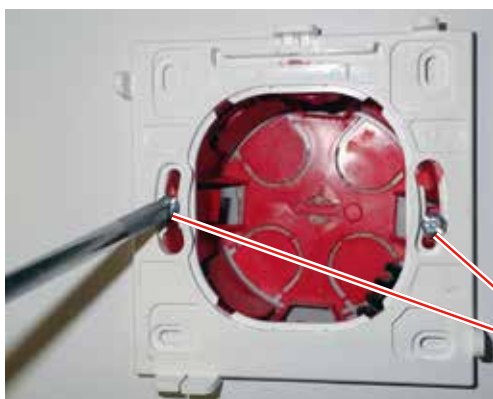



2.1.4. Sur un boîtier d'encastrement mural On a wall recessed box

2 vis de fixation
2 fixation screws

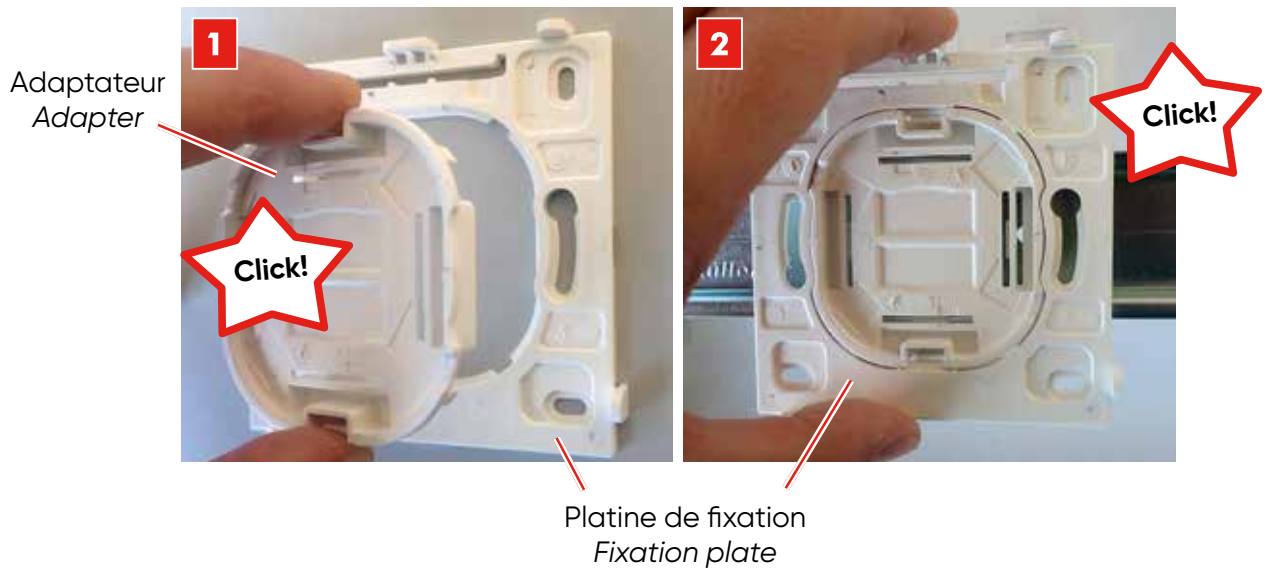
2.1.3. Sur rail DIN
On DIN rail



 La prise optique peut aussi se fixer par click sur une platine LEGRAND ou Schneider. *The optical outlet can also be fixed for click on a LEGRAND or Schneider plate.*



LEGRAND



Schneider

2.2. Fixation sans la platine
Fixation without the plate

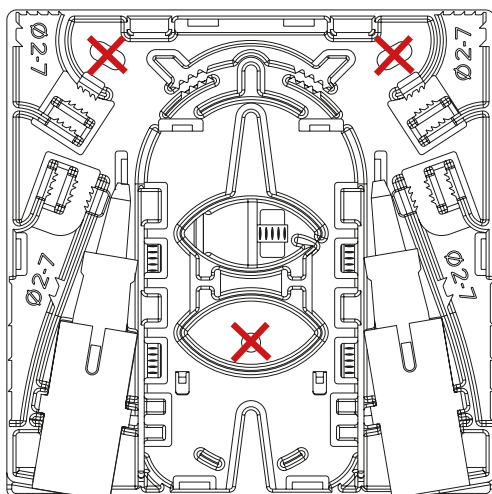

Fixation de la prise sans la platine avec les deux vis de fixation

Fixing the outlet without the plate with the two fixing screws

2.3. Ouverture de la prise
Opening the outlet

1. Appuyer des deux côtés, en bas du couvercle et soulever légèrement.
2. Appuyer des deux côtés, en haut du couvercle et tirer pour déclipser.

1. *Press the cover downwards on both sides and slightly lift the cover.*
2. *Press upwards on both sides and pull the cover to release it.*

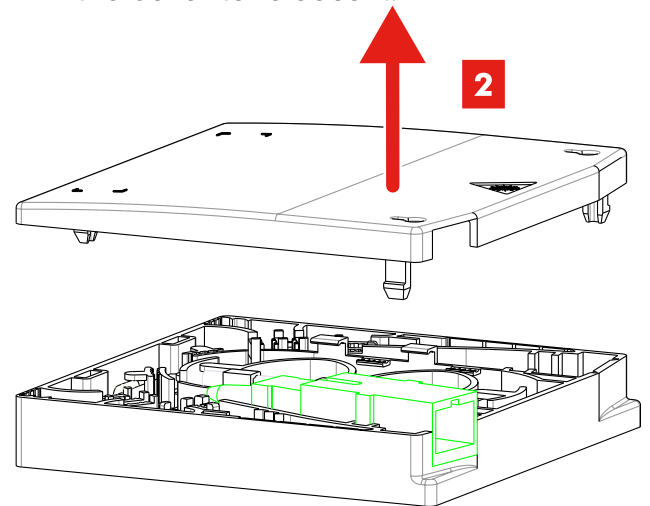
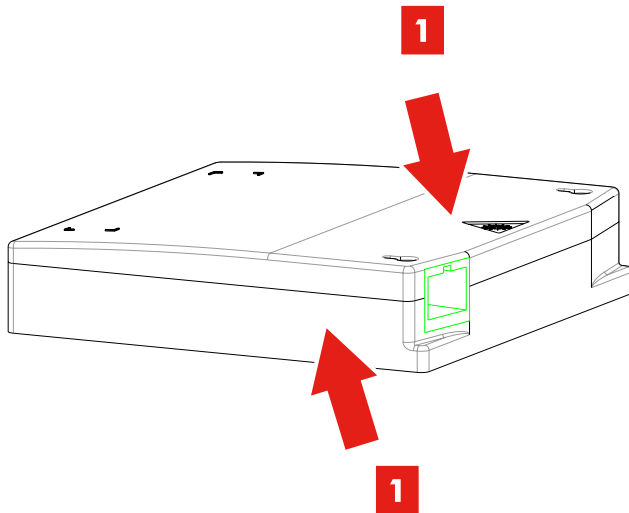

3. INSTALLATION D'UN CÂBLE
CABLE INSTALLATION

3.1. Préparation du câble
Cable preparation

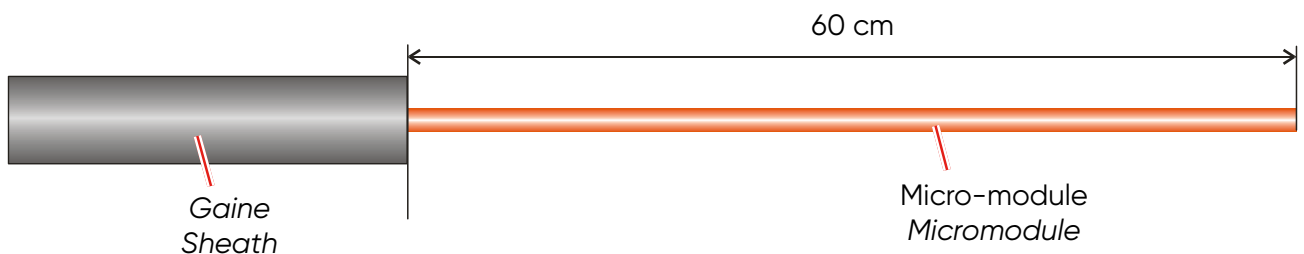

3.2. Installation du câble
Cable installation



Couper les entrées de câble selon configuration (en rouge) ainsi que les sorties de câble (en bleu).
Couper la patte selon la dimension du câble.(en orange)

Cut the cable inputs according to the configuration (red) and the cable outputs (blue)
Cut the leg according to the size of the cable (in orange).

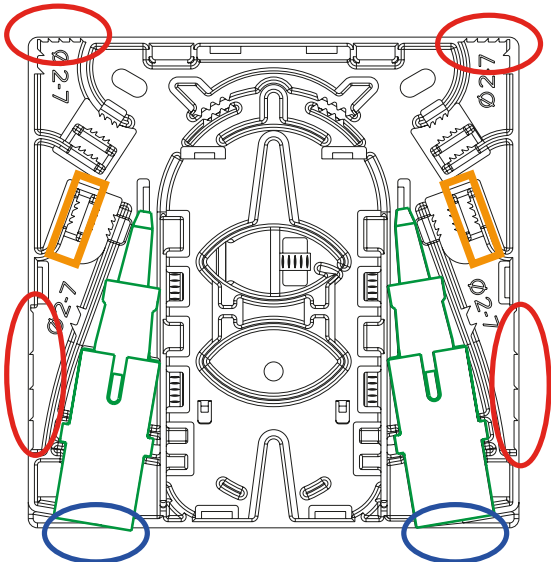

- | | |
|---|--|
| <ol style="list-style-type: none"> 1. Arrimer le câble (2-7mm) à l'aide du collier plastique 2. Dénuder le micromodule avant de rentrer dans la zone de lovage 3. Lover la fibre nue | <ol style="list-style-type: none"> 1. <i>Clamp the cable (2-7mm) with the plastic tie</i> 2. <i>Strip the micro-module before entering the coiling area</i> 3. <i>Coil the bare fibre</i> |
|---|--|

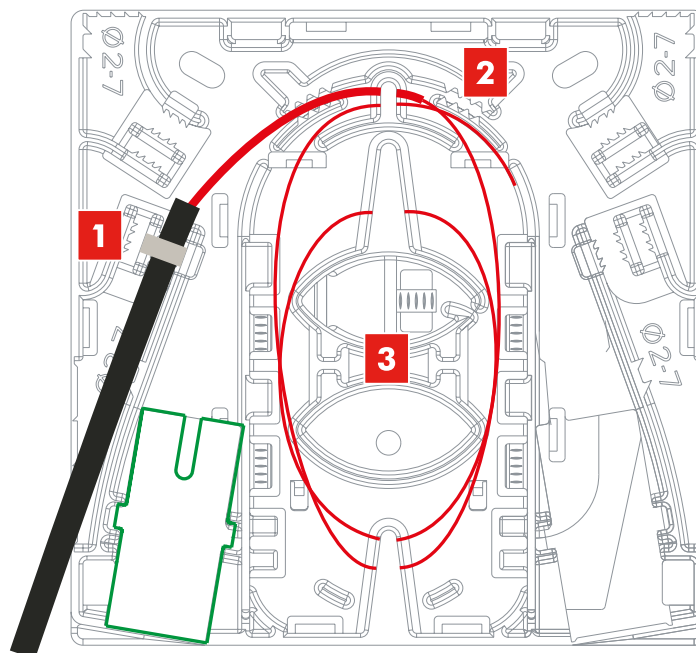

4. ÉPISSURAGE DES FIBRES FIBRES SPLICING

1. Dénuder la fibre de manière à conserver **2 cm** de micro-module.

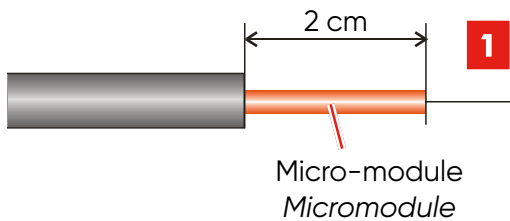

1. Strip the fibre so as to keep **2cm** of

Fibre nue
Bare fibre

2. Délover la fibre en attente.
3. Réaliser l'épissure.
4. Lover les fibres.

micro-module.

2. Uncoil the awaiting fibre.
3. Perform the splice.
4. Coil the fibres.

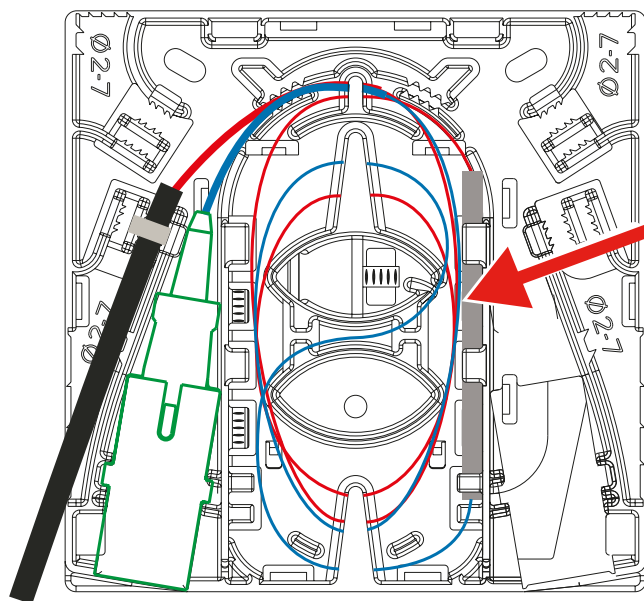
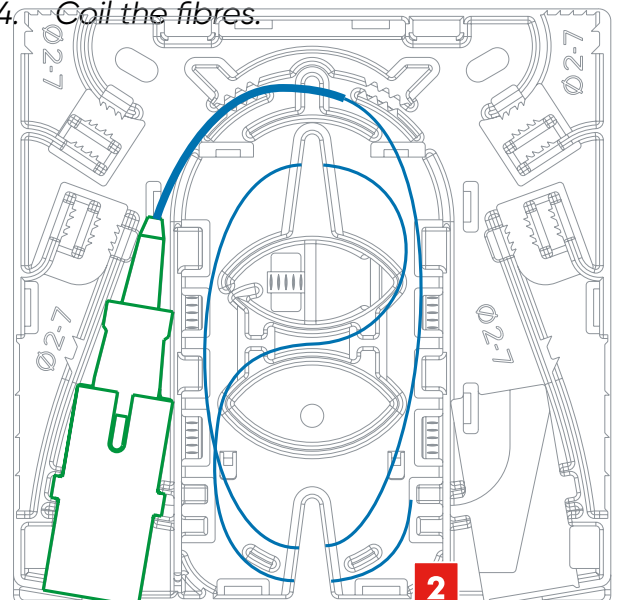
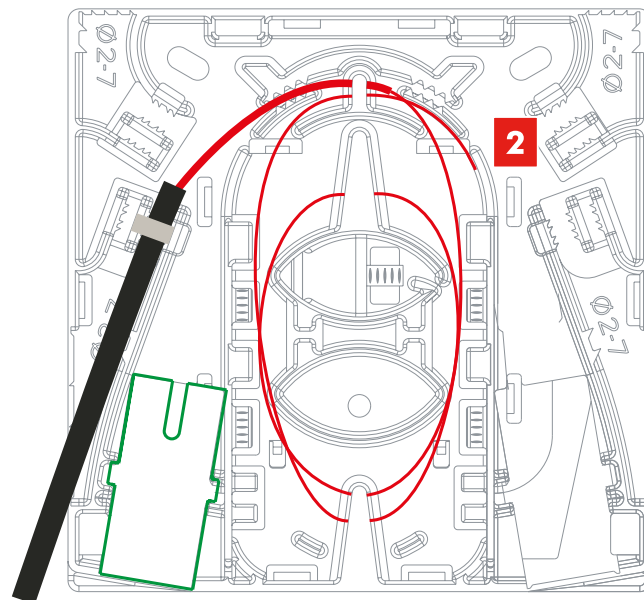

L'épissure peut-être en thermorétractable ou ANT.

The splice can be made of heat-shrinkable or ANT.

5. FINALISATION DE L'INSTALLATION
FINALISING THE INSTALLATION

Aligner la prise avec la platine et appuyer jusqu'au click.

Align the outlet with the plate and press until you hear an audible click.



6. RACCORDMENT DU CLIENT
CONNECTING THE SUBSCRIBER

i Le pictogramme  indique l'orientation correcte du détrompeur et la couleur du pigtail.

The  pictogram indicates the correct orientation of the polarising slot and the color of the pigtail.

Détrompeur **vers le haut**
Polarising slot **directed upwards**

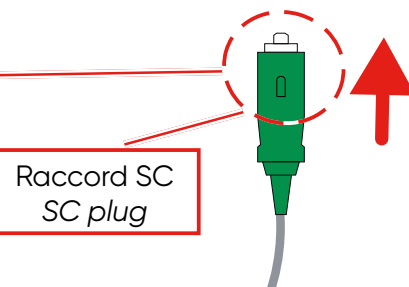
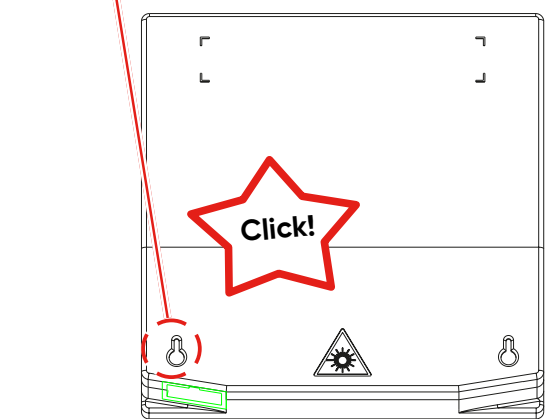
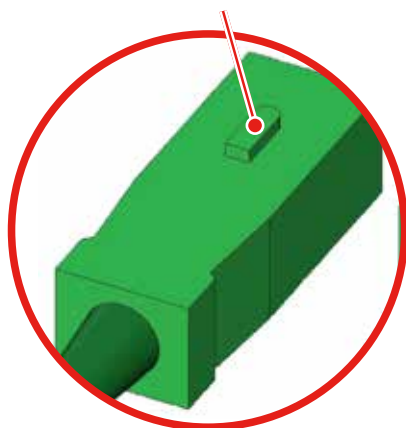

Raccord SC
SC plug

7. INSTRUCTIONS DE FIN DE VIE
END LIFE INSTRUCTIONS

| | | |
|---|---|--|
|  |  Emballage carton, sachet plastique <i>Cardboard, plastic packaging</i> |  Sachet zip réutilisable <i>Reusable zip bag</i> |
| |  Pièce métallique et plastique <i>Metal and plastic component</i> | WEEE / DEEE  Équipement électrique et électronique <i>Electrical and electronic equipment</i> |

Se connecter via LinkedIn
Connect via LinkedIn



En savoir plus sur Youtube
Learn more on YouTube

Visiter www.aginode.net
Visit www.aginode.net

Contactez-nous via
Contact us via
info@aginode.net

AGINODE
25, avenue Jean Jaurès
08330 Vrigne-aux-Bois
FRANCE
Tel. +33 (0) 3 24 52 61 61