



VERTHOR
BOÎTIER INTÉRIEUR D'ÉPISSURAGE-BRASSAGE
SPLICING-PATCHING INDOOR BOX



Tous les schémas, dessins, spécifications, plans et détails de poids, tailles et dimensions figurant dans la documentation technique ou commerciale de Nexans ont un caractère purement indicatif et ne sauraient engager Nexans ou être traités comme constitutifs d'une garantie de la part de Nexans.

All drawings, designs, specifications, plans and particulars of weights, size and dimensions contained in the technical or commercial documentation of Nexans is indicative only and shall not be binding on Nexans or be treated as constituting a representation on the part of Nexans.

Table des matières

Table Of Contents

1. DESCRIPTION	
OVERVIEW	3
1.1. PRÉSENTATION DU PRODUIT	
PRODUCT PRESENTATION	3
1.2. ACCESSOIRES FOURNIS (SELON CONFIGURATION)	
PROVIDED ACCESSORIES (ACCORDING TO CONFIGURATION)	4
2. OPÉRATIONS PRÉLIMINAIRES	
PRELIMINARY OPERATIONS	4
2.1. ACCÈS AU BOÎTIER	
ACCESSING THE BOX	4
2.2. PRÉPARATION DE LA CASSETTE (VERSION ÉPISSURAGE / BRASSAGE UNIQUEMENT)	
CASSETTE PREPARATION (SPLICING/PATCHING VERSION ONLY)	5
3. FIXATION MURALE	
WALL MOUNTING	5
4. MISE EN PLACE DU CÂBLE PRINCIPAL	
MAIN CABLE INSTALLATION	6
4.1. VERSION BRASSAGE SEUL	
PATCHING ONLY VERSION	6
4.2. VERSION ÉPISSURAGE / BRASSAGE	
SPLICING/PATCHING VERSION	7
5. RACCORDEMENT	
CONNECTION	9
6. FERMETURE DU BOÎTIER	
BOX CLOSING	10
6.1. BOÎTIER INSTALLÉ SANS JUPES	
BOX INSTALLATION WITHOUT EXTENSION COVERS	10
6.2. BOÎTIER INSTALLÉ AVEC JUPES	
BOX INSTALLATION WITH EXTENSION COVERS.....	11

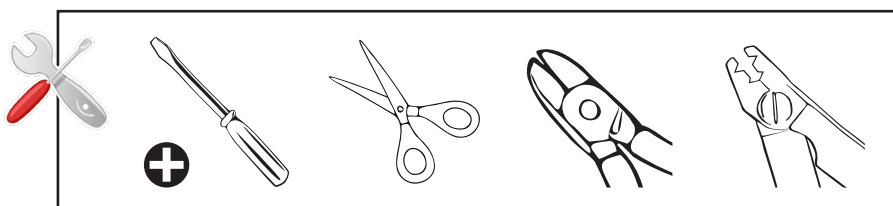

1. DESCRIPTION OVERVIEW

1.1. Présentation du produit *Product presentation*

- | | |
|--|--|
| <ul style="list-style-type: none"> 1- Capot 2- Corps 3- Bandeau de brassage équipé de raccords : 12 SC, 8 SC, 4 SC Duplex ou 8 ST, selon la configuration 4- Eléments de guidage 5- (Version épissure / brassage uniquement) Cassette montée sur platine pivotante avec support pour 12 épissures. | <ul style="list-style-type: none"> 1- Cover 2- Base 3- Patch panel equipped with adapters: 12SC, 8SC, 4SC Duplex or 8ST, according to configuration 4- Guiding elements 5- (Patching/splicing version only) Cassette mounted on swivelling plate with holder for 12 splices. |
|--|--|

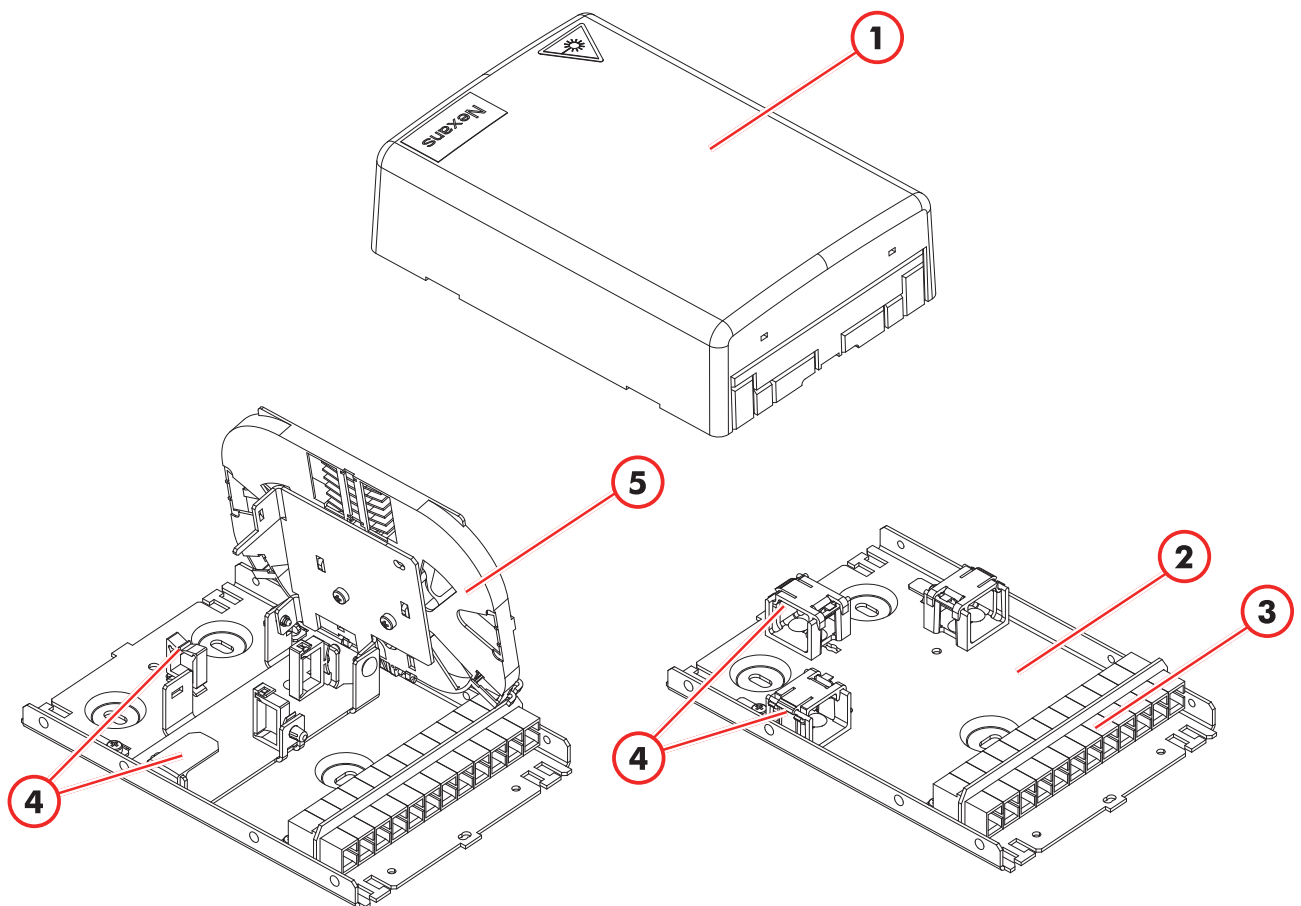
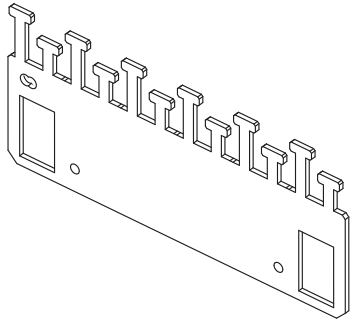

Fig. Version épissure / brassage
Patching/splicing version

Fig. Version brassage seul
Patching only version

1.2. Accessoires fournis (selon configuration)
Provided accessories (according to configuration)



Platine d'arrimage
Clamping plate

i Capacité max. : 25 pigtails ø 0,9-1,1 mm
 Max. capacity: 25 pigtails ø0.9-1.1mm

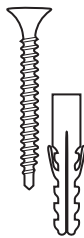

4 vis et chevilles de fixation
4 fixation screws and plugs



4 colliers plastique
4 plastic ties

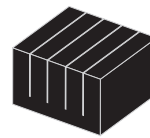

Peigne mousse
Foam comb

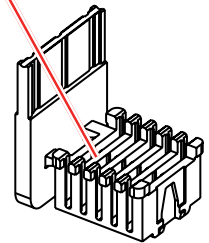

Peigne n° 12
Comb no 12

2. OPÉRATIONS PRÉLIMINAIRES
PRELIMINARY OPERATIONS

2.1. Accès au boîtier
Accessing the box

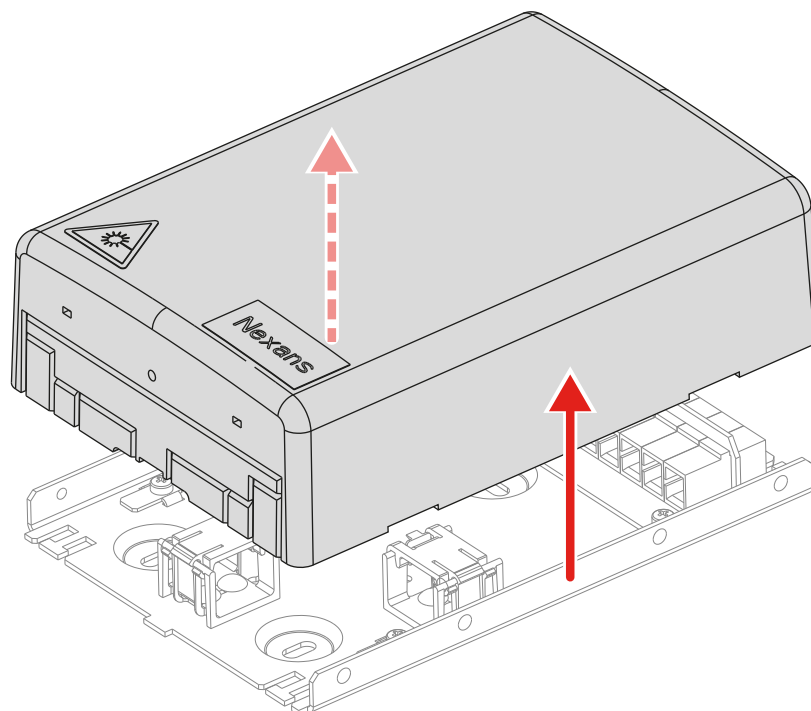

2.2. Préparation de la cassette (version épissurage / brassage uniquement)
 Cassette preparation (splicing/patching version only)

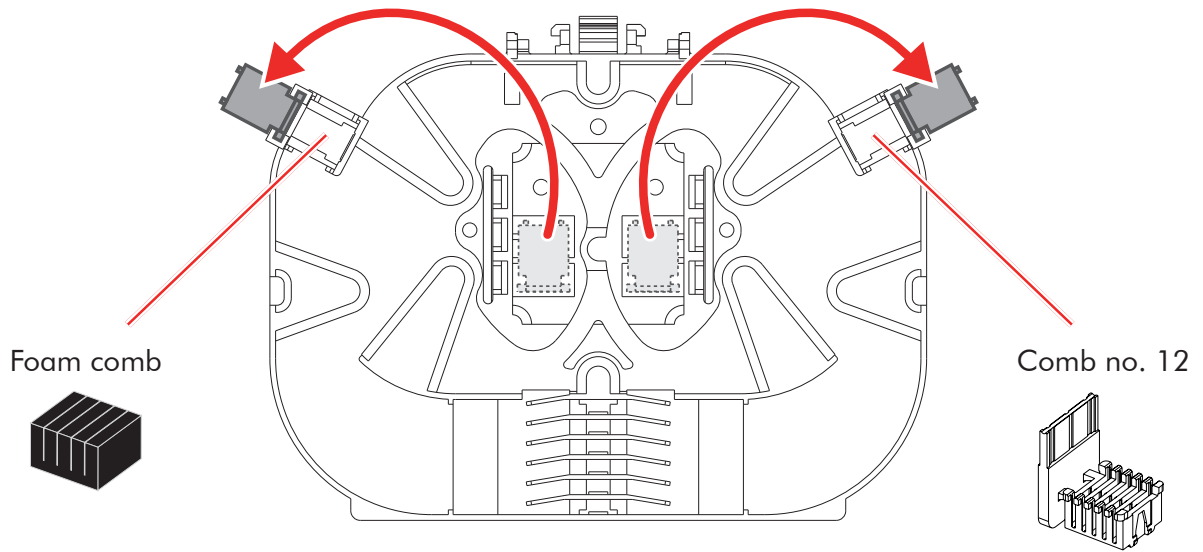

3. FIXATION MURALE
WALL MOUNTING

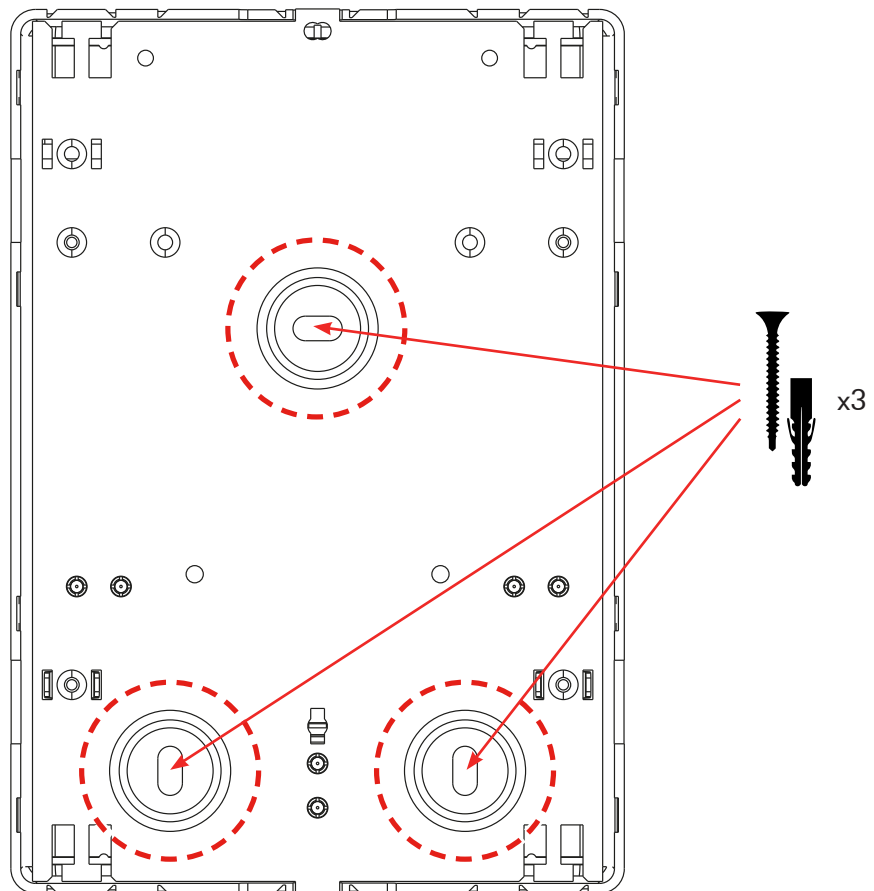

**4. MISE EN PLACE DU CÂBLE PRINCIPAL
MAIN CABLE INSTALLATION**

4.1. Version brassage seul
Patching only version

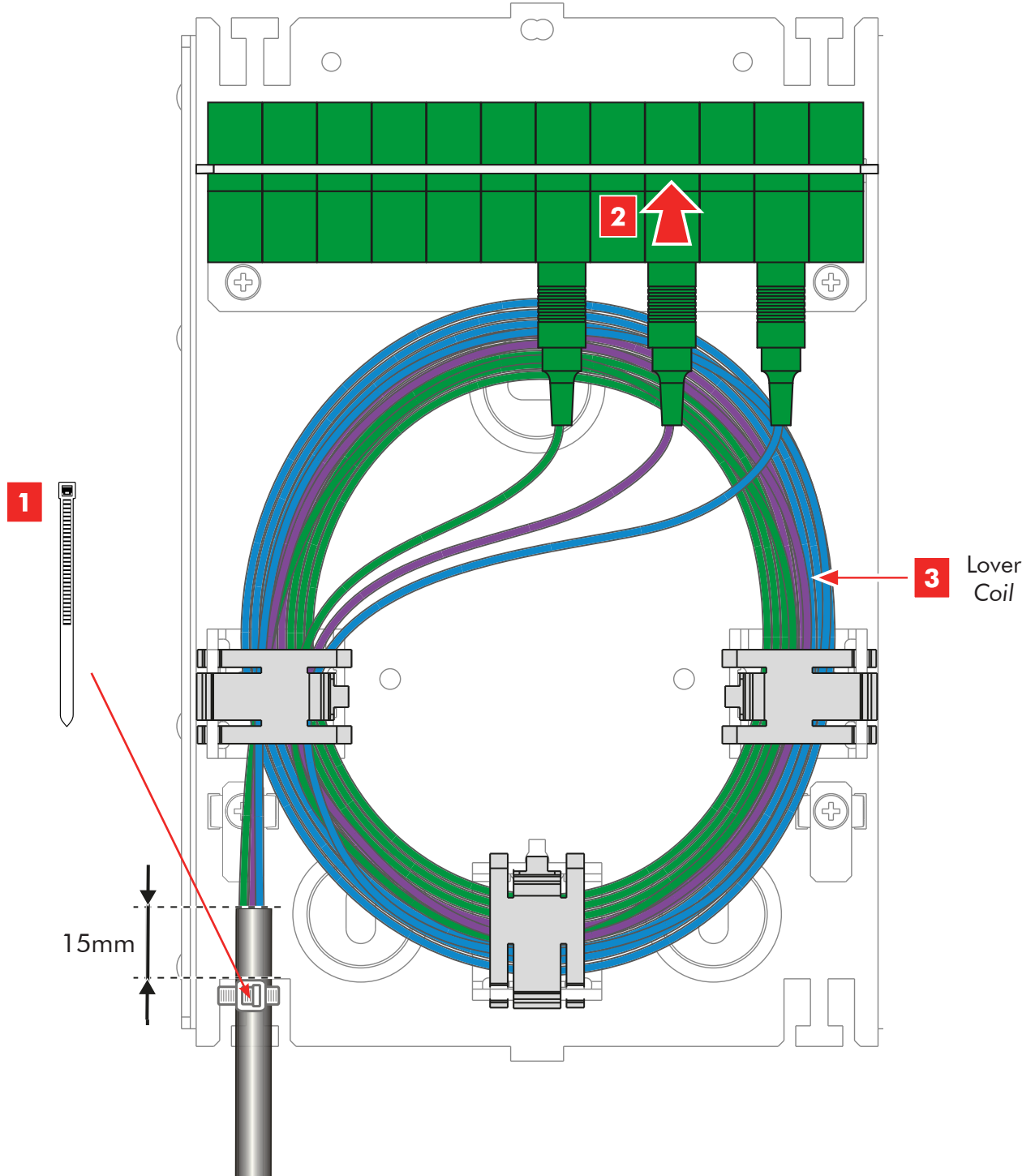

4.2. Version épissure / brassage Splicing/patching version

Longueur selon configuration
Length depending on installation

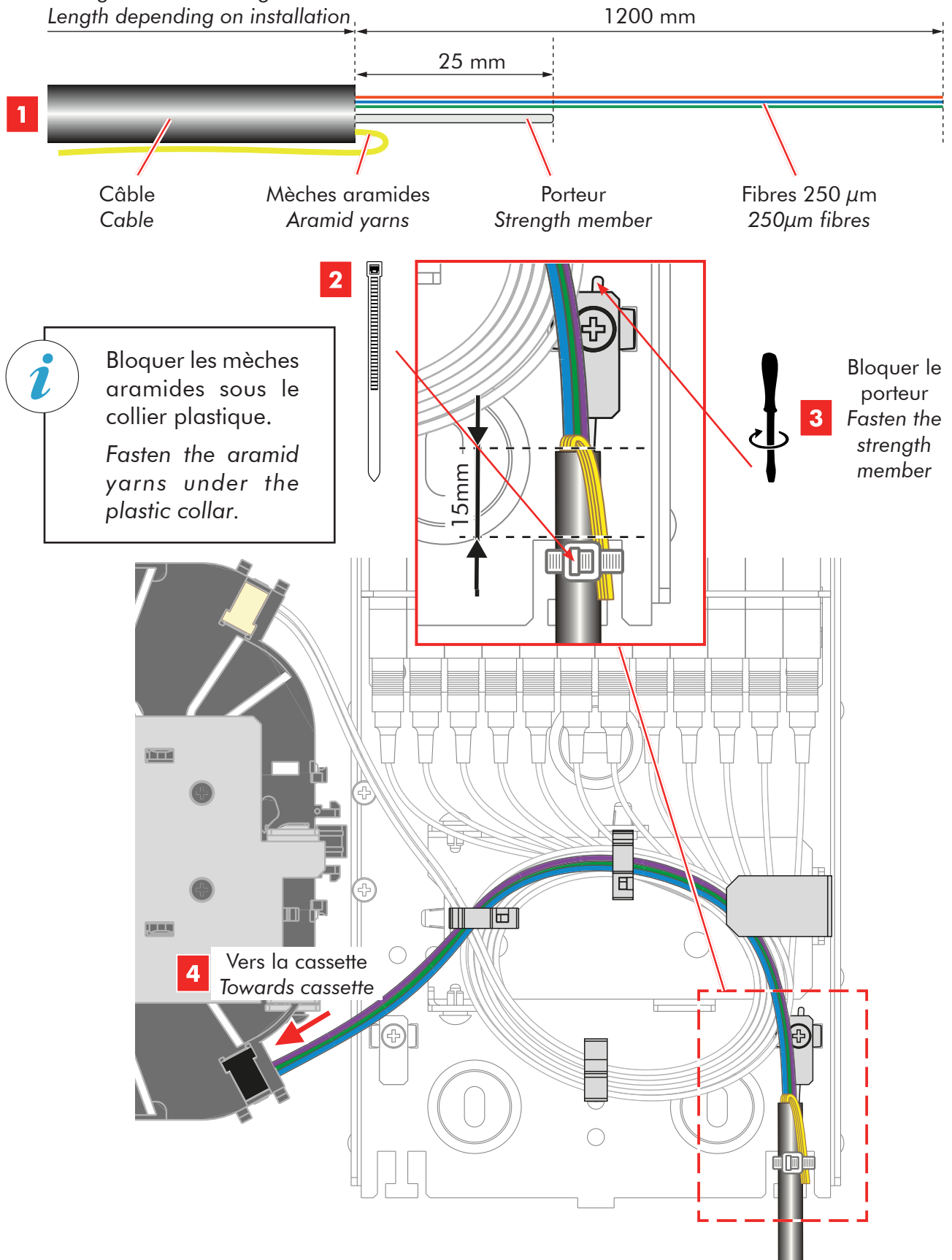

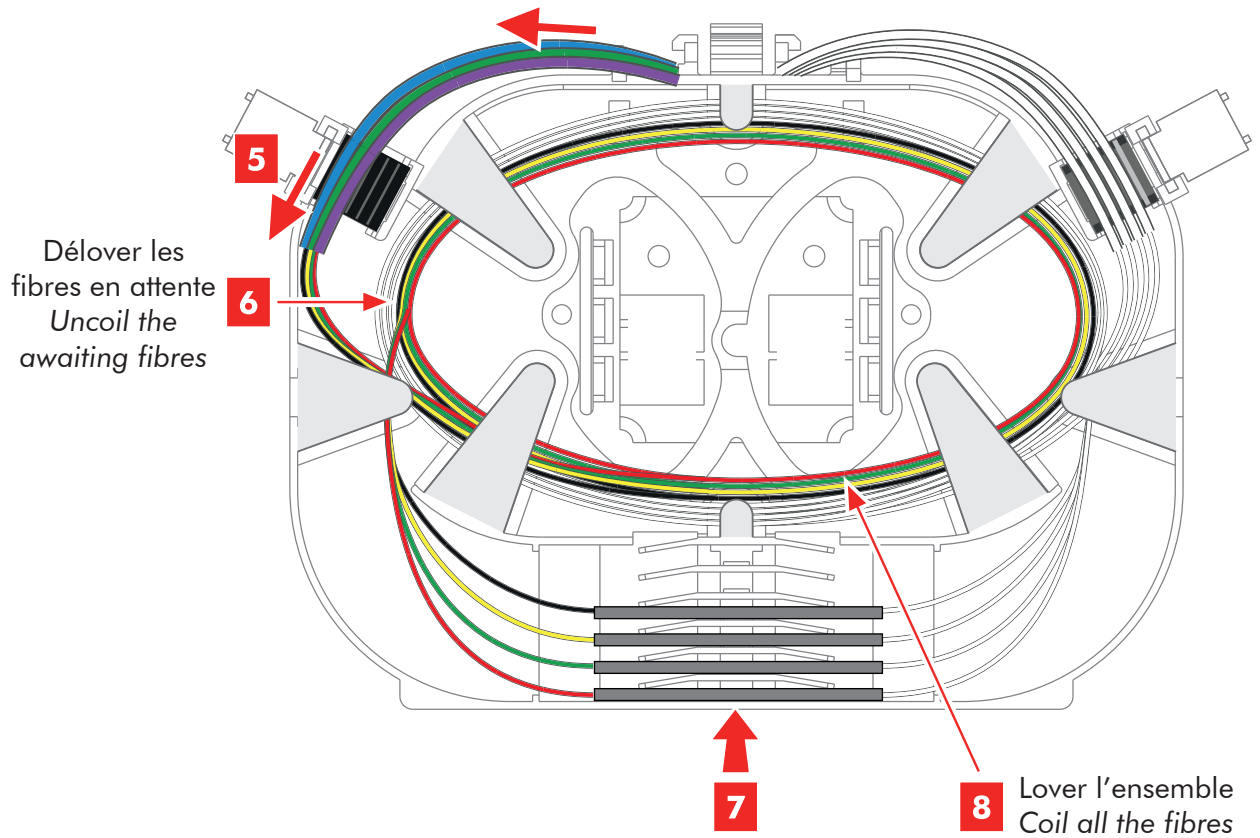

5. RACCORDEMENT CONNECTION

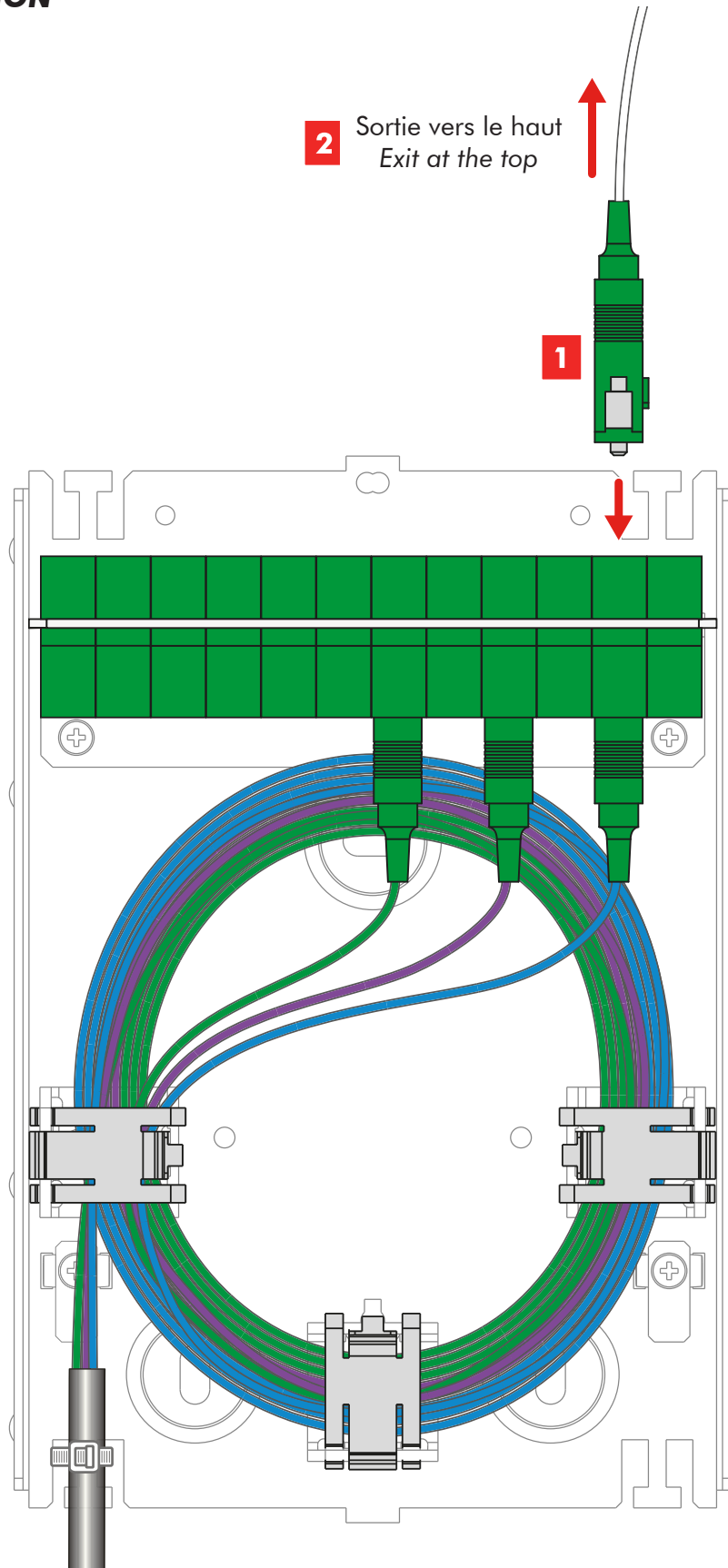

6. FERMETURE DU BOÎTIER BOX CLOSING

- 6.1. Boîtier installé sans jupes
Box installation without extension covers

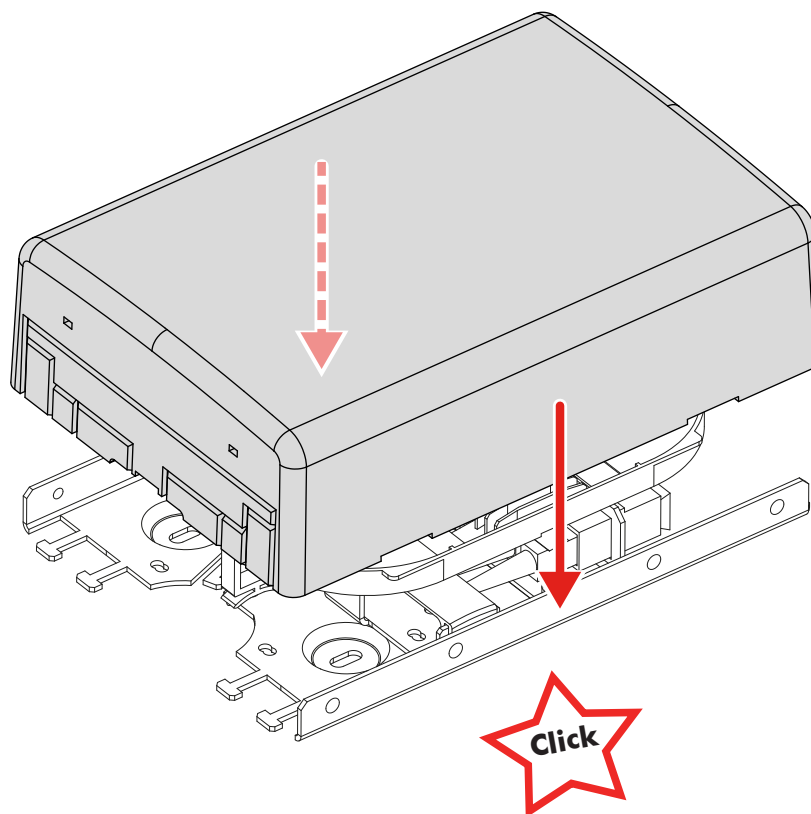

6.2. Boîtier installé avec jupes *Box installation with extension covers*

- | | |
|--|---|
| <ol style="list-style-type: none"> 1. Couper les obturateurs sécables appropriés des jupes. 2. Couper les obturateurs sécables du couvercle. 3. Clipser les jupes sur le couvercle. 4. Placer l'ensemble sur le boîtier. | <ol style="list-style-type: none"> 1. Cut the appropriate outputs from the extension covers. 2. Cut the outputs of the main cover. 3. Clip the extensions on the cover. 4. Place the assembly on the box. |
|--|---|



NEXANS INTERFACE**25, avenue Jean Jaurès - BP 11 - 08330 - Vrigne-aux-Bois - FRANCE****Téléphone : +33 (0) 3.24.52.61.61 Fax : +33 (0) 3.24.52.61.66**

Tous les schémas, dessins, spécifications, plans et détails de poids, tailles et dimensions figurant dans la documentation technique ou commerciale de Nexans ont un caractère purement indicatif et ne sauraient engager Nexans ou être traités comme constitutifs d'une garantie de la part de Nexans.

All drawings, designs, specifications, plans and particulars of weights, size and dimensions contained in the technical or commercial documentation of Nexans is indicative only and shall not be binding on Nexans or be treated as constituting a representation on the part of Nexans.